

Installation Guide

Architektur-Kamin

©2023

BRUNNER[®]
made in germany.

CONTENTS

1	Basic informations.....	2
2	Safety precautions.....	3
3	Equipotential bonding and lightning protection.....	4
4	Product description.....	4
5	Delivery contents.....	5
6	Requirements for location.....	5
7	Combustion air.....	7
8	Chimney and smoke pipe connection.....	8
9	Flue limiting device.....	8
10	Installaltion.....	9
11	Mounting instructions for EAS / EOS variants.....	11
12	Overview of fire safety and protection of other structures against heat.....	13
13	Connections and assembly.....	15
14	Building protection.....	17
15	Approved insulation materials.....	19
16	Drawings and technical data.....	

1 BASIC INFORMATIONS



All instructions delivered with products must be observed. We do not accept any warranty claim or liability for damage resulting from failure to observe these installation instructions!
Improper installation can cause injury and material damage!

The installation may only be carried out by a registered specialist.

Fireplaces equipped with a water boiler must be pressure-tested after hydraulic connection to the heating system. Masonry work may follow only after this pressure test. Ulrich Brunner GmbH does not cover any costs incurred by necessary dismantling of masonry for rework at water boiler installation or replacement of the boiler.

The floor space of the room must have a suitable structure and sufficient dimensions to ensure proper functioning of the fireplace.

Please note that other installation and assembly instructions are included in other packaging units!

Dimensioning of downstream heat accumulator must be according to valid stove-setting rules.

During installation of the fireplace, all dimensions and minimal clearances of the fireplace casing must be held as specified by the manufacturer.

Fireplaces that meet the requirements of DIN EN 13240 or DIN EN 13229 and that can only be operated as intended with closed combustion chamber door or that have a self-closing firebox door are suitable for multiple occupancy.

All binding national or EU standards and local regulations for the installation of fireplaces must be observed.

All valid stove fitting rules and regulations of local construction law must be observed and followed.

Please follow the relevant regulations of your country.

When these instructions are followed and all works are done properly, this will ensure a safe, energy-saving and environmentally friendly operation of the stove. Pictures shown are not to be considered as complete representations of any kind.

Subject to technical and assortment changes.

Please notify your supplier of any damage which might have occurred during transport.

Please keep these instructions.

2 SAFETY PRECAUTIONS

Fireplaces may be set up only in rooms or areas with no risk of danger due to their location, structure or intended use.

Working on the stove

Installation, commissioning, servicing and maintenance works on the product may be carried out only by an authorized stove-fitter. Safety and efficiency of the system depend on this!

Working with electronics

Switch off the emergency switch or circuit breaker, and secure them against switching on again.



Fireplaces with external air supply are not independent from room air supply and must be considered and designed as roomsealed fireplaces. In connection with a ventilation or extraction system, we recommend the use of a negative pressure safety device USA.



If additional parts are installed on the fireplace which are not approved for this appliance by Ulrich Brunner GmbH (for example, an external control unit), it is a customized product that meets customer requirements. The resulting fireplace insert is not type-tested; the declaration of performance of this fireplace insert will be no longer valid.

The CE mark must be removed from the heating insert!

The responsibility for installation (according to TROL) and operation lies exclusively with the specialist craftsman!

Installation must be carried out by an authorized stove-fitter, because safety and efficiency of the system depend mostly on proper installation of the product. All valid stove fitting rules and regulations of building law must be observed and followed. Make sure to instruct the owner or user about the functions and controls of the system and possibly installed safety devices.

Fireplaces must be built to ensure safe operation and fire safety in order to eliminate possible risks and unacceptable loads. They have to be ready for use over an adequate period of time.

Make sure to instruct the owner or user about the functions and controls of the system and possibly installed safety devices.

Remember to use only genuine replacement parts.

Stoves with water boilers are ready for use only with a fully functional boiler section.

3 EQUIPOTENTIAL BONDING AND LIGHTNING PROTECTION



ATTENTION - lightning protection, earthing, equipotential bonding.

When connecting fireplaces with / without power connection to metallic exhaust systems (stainless steel exhaust systems, metal chimneys, refurbished chimneys, ...), the national regulations and existing association guidelines must be observed. The requirements and the design of lightning protection systems, surge protection as well as earthing and equipotential bonding for exhaust systems are regulated.

Equipotential bonding and surge protection ("internal lightning protection") have been mandatory in new buildings since 2016. Equipotential bonding is therefore required by law for metallic exhaust systems. Metallic chimneys must always be integrated into the building's earthing system. If there is also a lightning protection system ("external lightning protection"), the exhaust system must be integrated into the lightning protection system.

The measures provided in individual cases must be carried out by qualified electricians and / or lightning protection specialists.

Overvoltage protection measures for electrical and information technology systems are not dealt with in the standards mentioned and must be created individually on site via the fine protection / terminal device protection.



The legally provided equipotential bonding is not covered by the connection of the fireplace with / without a power connection to the protective conductor!



In case of damage to current-carrying components caused by non-professional measures for lightning protection, earthing and equipotential bonding, there is no entitlement to guarantee and warranty.

4 PRODUCT DESCRIPTION

Fireplaces manufactured by Ulrich Brunner GmbH are designed and approved as self-closing devices according to EN 13229. Fireplaces with lifting doors can be retrofitted for open door use with available counterweights. Please note, that fireplaces intended for open door use may be connected to a separate chimney only.

Combustion air is supplied through a provided connecting piece. The volume of supplied combustion air can be controlled by using a combustion air regulator. These fireplaces are designed for closed installation without any vents (hypocaust principle). The hypocaust design must ensure uninterrupted transfer and even distribution of heat inside the casing, preventing all parts of the heating chamber from overheating. Dimensioning of heat projecting walls of the casing must be adjusted to performance data of the heating device. Thickness of insulation for building walls surrounding the fireplace as stated in technical data has been determined during continuous operation with open air vents (safety test according to EN 13229 - heat transfer coefficient of the tested wall at 0,7 W/m²K), and must be adjusted for different conditions (for example, by providing air ventilation for walls).

When installing electric or electronic parts (controllers, sensors, cables...) or water-conducting parts, please consider the max. permitted surrounding temperatures for these components.

When setting up a closed system using a fireplace with lifting door, please keep in mind that the surrounding temperature for pulleys of the door lifting mechanism must not exceed 150°C.

Hood	Door	Heating surface	Designation	Operation mode	Chimney	Start-up flap	Damper flap
steel hood	self-closing	-	EN 13229 W	nominal load	multiple connection	-	yes
steel hood	non self-closing	-	EN 13229 W	open door / nominal load	separate connection	-	yes

5 DELIVERY CONTENTS

The fireplace is delivered on a disposable pallet. The fireclay combustion chamber linings are delivered in a cardboard box on a separate pallet. Parts of deflector plate (if fitted) are stowed inside the combustion chamber.

All necessary accessories used for opening and cleaning of the glass door are inside the unit.

Outside on the protective packaging, you can find a label with detailed description of fireplace type. Please check the contents of your delivery! Any damage occurred during transport or missing parts must be immediately indicated to the supplier!

Position of the identification plate

A factory identification plate is located on the fireplace, below the glass door, where it cannot be seen after installation. Additionally, a second identification plate with the same data is attached to your product documentation.

6 REQUIREMENTS FOR LOCATION

Possible locations for a wood-burning stove or fireplace are only such rooms, where no danger can occur, if only the instructions for use are being followed and the system is properly used. The state, structure and intended use of the room must be considered, when choosing the location.

Please consider the massive weight of the system. If the floor is not strong enough to bear such load, it has to be distributed by suitable means.

A heating device **may not be located** in the following rooms:

1. Where sufficient volume of combustion air is not guaranteed.
2. Where flammable materials or explosives are stored, manufactured or processed.
3. Which are commonly accessible. Stairways in residential buildings with access from only two flats are not considered as commonly accessible rooms.

4. Where exhaust fans of ventilation or air heating systems are running, unless safe operation of the fireplace is ensured. This is ensured, when:
- The systems are causing only circulation of air within the room.
 - The systems are equipped with safety devices, which automatically and securely prevent negative pressure in this room.
 - If simultaneous operation of fireplace and ventilation systems is prevented by safety devices.
 - If the total negative pressure level caused by the stream of combustion air of the fireplace and the airflow volume of the ventilation systems in this room and other rooms included in one ventilation system does not exceed 0.04 mbar. This must be ensured even if easily accessible controls of the ventilation system are being manipulated or removed.
 - If exhaust gas flow is being monitored by special safety devices.
 - If the construction type or dimensioning of the systems are excluding the possibility of dangerous negative pressure.

Please consult the location of your fireplace, chimney connection and combustion air supply with your local chimney sweep.

7 COMBUSTION AIR

Sufficient combustion air supply

A fireplace may be installed only in rooms, where sufficient combustion air supply is guaranteed. Normal operation requires sufficient air supply using a separate **combustion air connection** for the fireplace.

Sufficient combustion air supply is present, when by natural means or using technical equipment a combustion air volume of 12,5 m³ per 1 kg fuel throughput can stream into a room with wood-burning fireplace over a period of 1 hour at calculated negative pressure below 0,04 mbar (4 Pa) against outside air pressure. This is equivalent to a speculative heating power (PLF) of 8 kW per 1 kg fuel throughput.

When other fireplaces are in operation in the same room or different rooms included in one room combination, these fireplaces require at least 1.6 m³ of combustion air per hour for each kW of their total rated heating power. When a room combination contains only a small volume of air and the building is relatively air-tight, a separate combustion air supply from outdoors is required.

Combustion air supply is ensured in rooms with at least one window or one door which can be opened to outside of the building, or when these rooms are directly connected or interconnected with other rooms of such type. Rooms considered as directly connected or interconnected, can be only parts of one apartment or one facility of other kind. Particular attention to combustion air supply is to be paid, when exhaust fans and other heat generators in the same room combination are operated, or when multiple heating devices are connected to one single chimney.

Ventilation systems in this room combination cannot create negative pressure, which could affect the functioning of the fireplace. Exhaust ventilation systems operating in the same room or room combination together with fireplaces, can cause many problems.

Combustion air ducts

If external combustion air supply is necessary, it must be connected directly to the air supply connecting piece of the fireplace, to prevent possible air drafts.

The combustion air duct must have sufficient cross-section. It must be laid using the shortest way and without unnecessary bends, to reduce flow resistance. Combustion air duct dimensioning must be according to EN13884; flow resistance has to be estimated by calculation and must be taken into account!

Components of combustion air duct must be made of non-flammable, dimensionally stable and abrasion resistant materials (DIN 4102 A1 or Class A1(B2) according to DIN EN 13501-1); they must ensure tightness and be accessible for inspection and cleaning.

Thermal insulation is necessary from the fire-protection point of view, if air temperatures >85°C are possible.

Temperatures below dew point can cause water condensation, therefore appropriate insulation must be used.

For buildings with more than two storeys and when crossing fire protection walls, the construction of these ducts must prevent fire and smoke from penetrating other fire protection zones (their components must have a fire resistance rating of >90 minutes (F90)). See also national building law.

If the external air supply duct has a separate flap for closing, the position of this flap must be recognizable. It must be ensured, that the external air supply flap is open until the fire is burning. Air suction grilles or flaps cannot narrow the free cross section.

Remember about noise protection!

8 CHIMNEY AND SMOKE PIPE CONNECTION

Chimney and smoke pipe connection design must be in accordance with DIN 18160.1 or DIN EN 15287-1; dimensions must be calculated according to DIN EN 13384.

Connection of multiple fireplaces to the same chimney is possible, when it can be proven that the chimney is suitable, even if the design of these fireplaces is different (calculation of flow and thermal balance and approval from chimney sweep are necessary). However, it is not possible for fireplaces designed for open door use. Remember to use a separate chimney connection in this case.

If the connecting pipe between additional reheating devices (radiators, storage mass) and chimney is a steel flue gas pipe, it must be suitable for this application, it must conform to DIN EN 1856-2 standard and have a CE mark. The connecting pipe must be connected directly to the chimney.

A soot fire resistant chimney of T400 type is necessary for safe operation.

All smoke pipe connections must be sealed tightly! Remember to provide access for cleaning!

9 FLUE LIMITING DEVICE

It is recommended to install a flue limiting device in the smoke pipe connecting piece. The flap must be easy to operate and the position of the flap must be recognizable from outside by looking at the handle. The flap must retain its desired position and cannot close by itself. The damper flap must have openings around it, that are not less than 3% of the cross-sectional area, but at least 20 cm² wide.

10 INSTALLATION

CAUTION: It is absolutely necessary to observe fire safety guidelines regarding heat insulation and ventilation openings. When too much wood is loaded into an Architektur-Kamin fireplace, the chimney and/or surrounding structures/furniture may become overheated. Fire hazard!

Set the Architektur-Kamin vertically in the desired location. Any differences in height can be compensated using the adjustable feet. Please respect the admissible floor load. For units with lifting doors it is necessary to remove the transportation locks (see labels on both sides of the lifting door).

Before you begin the construction work, please check the self-closing door function first and then secure the glass door in the highest position.

The air control element is supplied together with the unit. Insert the control element into the recess of the frame in front of the glass.

Please advise the user not to remove the air control element, otherwise the setting of the combustion air will not be visible. Risk of deflagration!

Architektur-Kamin 45/101 and 38/86

If the hot-air hood has not yet been fitted at the factory, two people can easily lift it onto the body and screw it in place (see picture opposite). The screws and clamps (X) are included to the corpus as accessory.

In this case make sure that the lugs of the screw connection will not damage the cable pulleys.

Be sure to align the hot-air hood in the middle. This must also be done if the hood has already been installed at the factory!

The hot air outflow from the hood is not symmetrical. The heat exchanger tubes are ascending to one side.

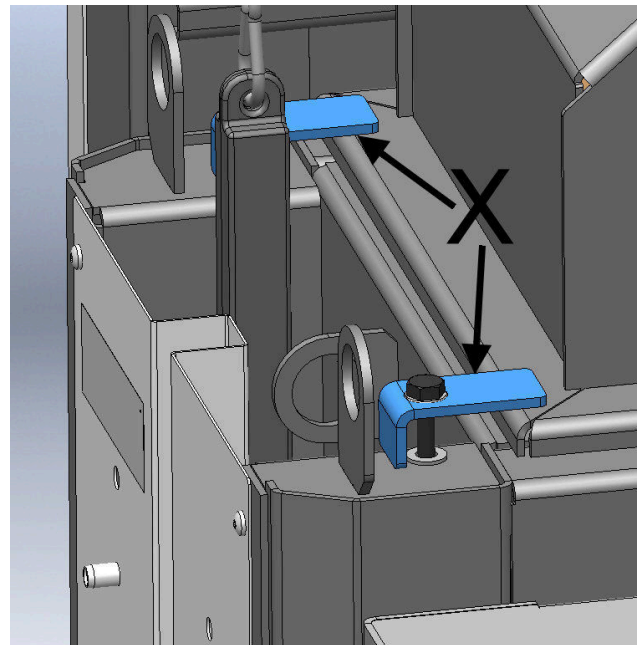

Im. 1: Tighten clamps

The vermiculite plate (Y) is placed on the side of the heating gas outlet as shown in the adjacent picture, that the hot gases are forced to completely bypass the deflection.

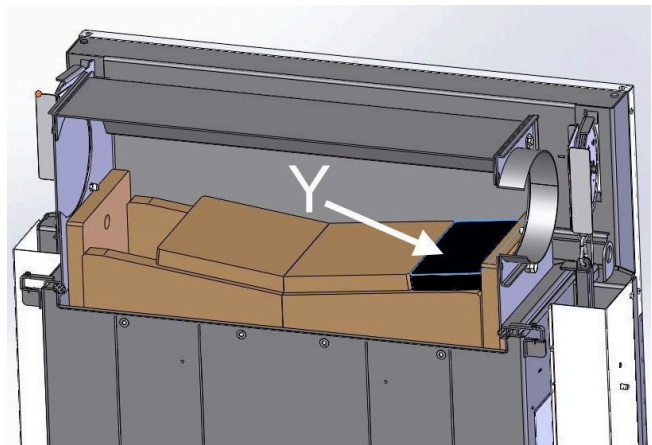

Im. 2: How to place the vermiculite plates

Mount the two heat protection shields (Z) as shown in the picture. Here, the heat protection shield should be clamped between the two existing nuts.

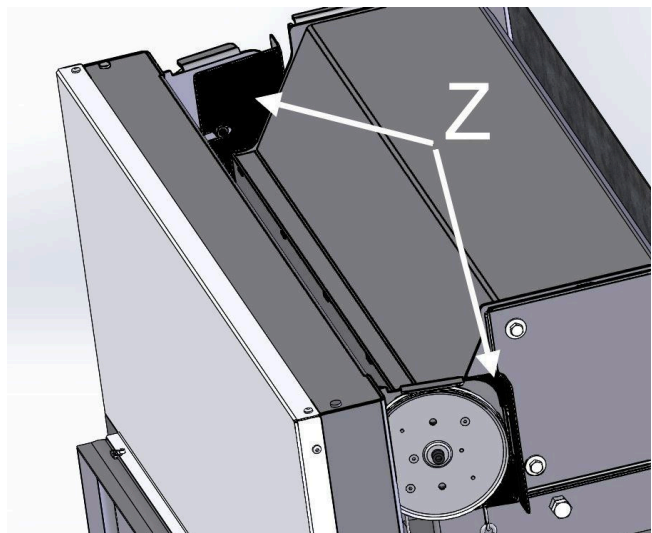

Im. 3: Installing of the heat protection shields

Mounting of combustion chamber:

The chamotte of the combustion chamber must be assembled according to installation instructions attached.

The height of the control lever can be adjusted.

Pull out the control lever and turn the grub screw (X) to the desired position.

Re-insert the control lever and check the function. The operating lever must not rest on the frame or impair the function of the firing door.

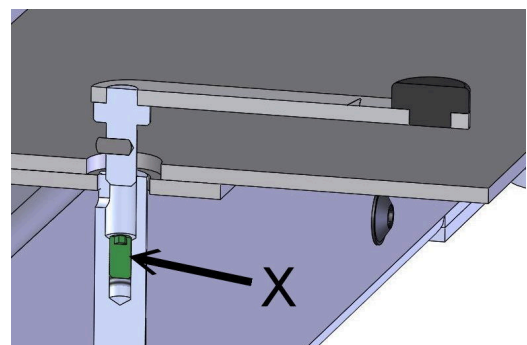

Cladding of fireplace

Do not wall in the door frame. An expansion joint must be provided between frame and cladding material.



11 MOUNTING INSTRUCTIONS FOR EAS / EOS VARIANTS

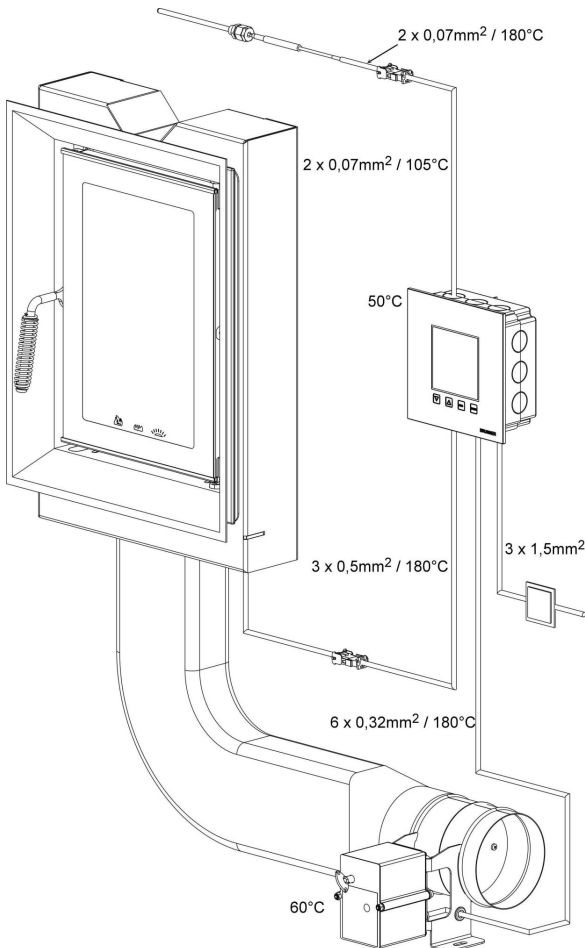

Im. 4: Schematic layout of EAS

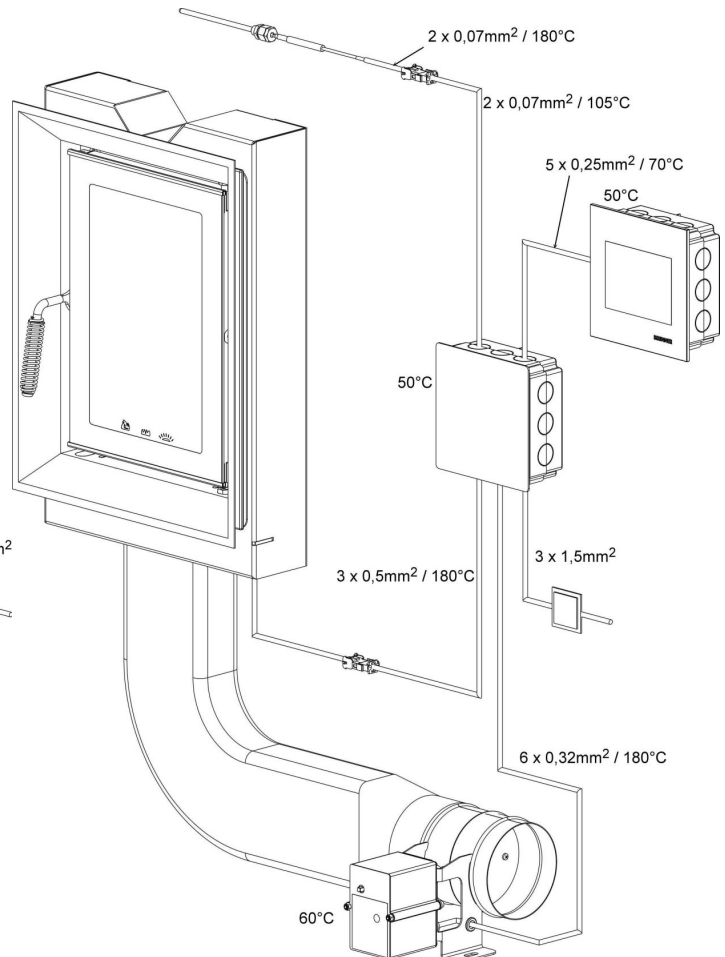

Im. 5: Schematic layout of EOS

The indicated temperatures are maximal permissible temperatures of components!
 The indicated cable dimensions are minimal dimensions!

Installation of electronic components must be prepared and performed carefully. Please pay attention to the following points:

- The flush-mounting box must be fitted in level and clean, to ensure easy, tension-free installation of electronics.
- Prevent any physical contact with electronic components - possible electrostatic discharge can damage them.
- Humidity can affect electronic components. Therefore, it is very important to ensure clean and dry installation of electronics.
- If possible, avoid installation of electronic components in exterior walls to prevent risk of corrosion at temperatures below dew point.
- The control unit must not be installed in hot parts of the tiled stove casing.
- The selected type of installation must ensure that temperatures do not exceed +40# (140°F) and the unit is not exposed to direct heat radiation.

For units with external air supply, the motorized combustion air flap assembly cannot be installed in such way that the motor is located under the flap. Condensate could penetrate the motor and destroy it.

To avoid risk of damage, all cable conduits leading from electronics into the heating chamber must enter at the bottom of the stove casing. Cable conduits cannot end in upper parts of the heating chamber due to excessive temperature.

All electronic components must be accessible after installation for revision and replacement. When selecting place of installation, keep in mind the max. permitted temperature for the component. Components cannot be installed in closed spaces; proper ventilation must ensure sufficient heat discharge.

12 OVERVIEW OF FIRE SAFETY AND PROTECTION OF OTHER STRUCTURES AGAINST HEAT

Fireplace without convection casing

(shown on the example of an Eck-Kamin fireplace)

Installation in front of or next to an adjacent wall (U value $\geq 0.4 \text{ W/m}^2\text{K}$):

Installation in front of or next to a flammable wall (U value $\leq 0.4 \text{ W/m}^2\text{K}$):

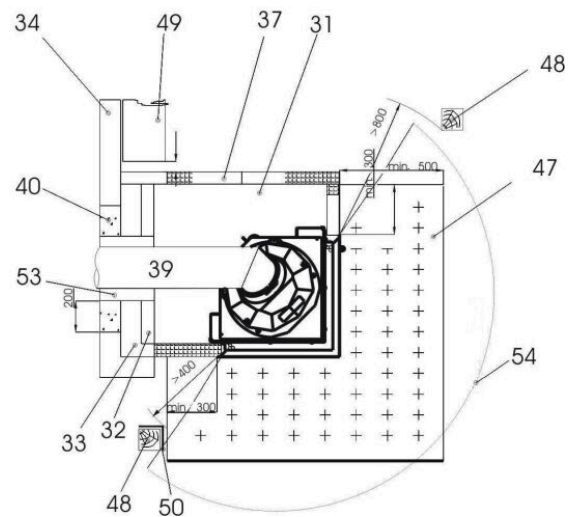
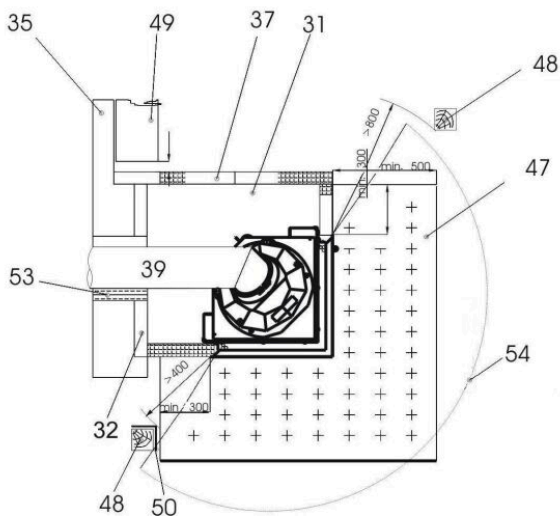
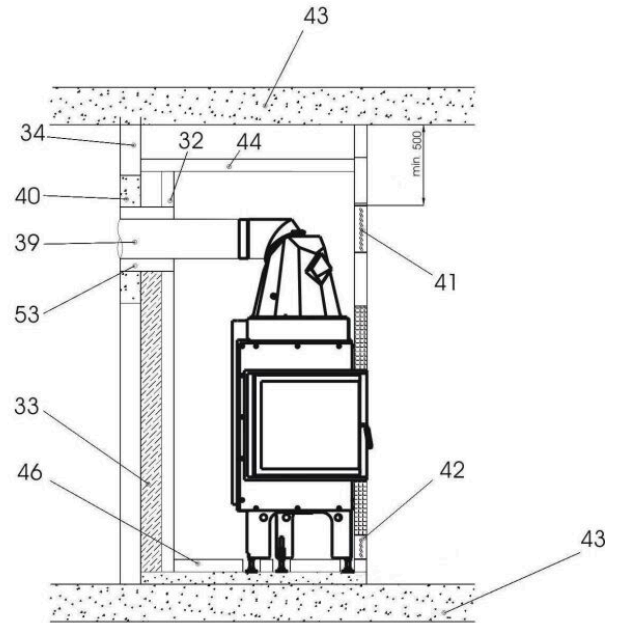
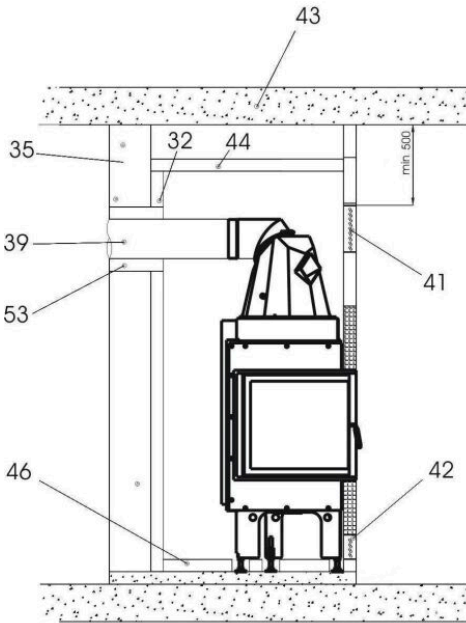

Im. 6: Basic principles of fire safety and heat insulation

Number reference:

21	Heating gas pipe
31	Convection space, distance between fireplace surface and external cladding / thermal insulation
32	Thermal insulation; see "Approved insulation materials"
33	Brick lining, at least 10 cm, mineral building materials, such as bricks according to DIN 105 or sand-lime bricks according to DIN 106
34	Protected wall: these are walls from flammable materials or containing flammable materials, main walls from reinforced concrete, as well as all walls with built-in furniture or wooden panels behind them (heat accumulation).
35	Adjacent walls: walls from mineral building materials, such as aerated concrete, bricks, sand-lime bricks, without flammable objects behind them.
36	Convection space, distance between reheating surface and thermal insulation
37	Active (heat-transferring) trim made of non-flammable materials (A1 class according to DIN EN 13501-1), such as ceramic stove tiles, fireclay bricks or plates.
39	Smoke pipe connecting piece
40	Fire protection on smoke pipe entrance
41	Warm air grating/opening
42	Circulating air grating/opening
43	Room ceiling
44	Thermal insulation for protection of room ceiling
46	Thermal insulation for protection of floor
47	Non-flammable floor covering
48	Structure made of flammable materials
49	Furniture or flammable objects on adjacent wall
50	Air cooled heat protection
51	Distance between floor insulation and air intake
52	Decorative beam over fireplace door
53	Thermal insulation of the smoke pipe connecting piece
54	Heat radiation range
	Fireplace
	Reheating surface
	Heating gas pipe
	Convection casing
	Convection air duct

13 CONNECTIONS AND ASSEMBLY

Heating flue / smoke pipe connecting piece

Heating gas pipe (21) between heating device and downstream heat radiator or storage mass, as well as the smoke pipe connecting piece (39) connected to chimney must be made of heat-resistant steel with CE mark. The connecting pipe must be connected directly to the chimney. When the connecting piece is leading through structures made of flammable materials, like protected walls (34), then the connecting piece must be insulated to specified thickness, and additionally, the surrounding area of about 20 cm around this insulated piece must be protected by mineral, non-flammable building material (40). The connecting piece must be also insulated in the area of active back ventilation with suitable insulation material to at least 3 cm thickness.

In the chimney entrance area it is necessary to provide an opening for measurements and revision.

All smoke pipe connections must be sealed tightly!

Outside air duct / combustion air pipe

If external combustion air supply is necessary, it must be connected directly to the air connecting piece of the heating device, to prevent possible drafts.

The combustion air duct must have sufficient cross-section. It must be laid using the shortest way and without unnecessary bends to reduce flow resistance. Combustion air duct dimensioning must be according to EN13884; flow resistance has to be estimated by calculation and must be taken into account!

Components of combustion air duct must be made of non-flammable, dimensionally stable and abrasion resistant materials (DIN 4102 A1 or Class A1(B2) according to DIN EN 13501-1); they must ensure tightness and be accessible for inspection and cleaning. Thermal insulation is necessary from the fire-protection point of view, if air temperatures above 85°C (185°F) are possible. Temperatures below dew point can cause water condensation, therefore appropriate insulation must be used. For buildings with more than two storeys and when crossing fire protection walls, the structure of these venting lines must prevent fire and smoke from penetrating other fire protection zones (see regional building law).

If the outside air duct has a separate flap for closing, the position of this flap must be recognizable. It must be ensured, that the outside air flap is open until the fire is burning. Air suction grilles or flaps cannot narrow the free cross section.

Convection space

The stove/fireplace insert must be surrounded by convection space (31/36). When the room air is streaming through the convection space, the heat being set free during combustion is led away into the room. The convection space must be insulated against all surfaces, which are not parts of heat projecting walls of the fireplace. Insulation thickness: see technical data. The convection space is the distance between the fireplace insert and heat insulation and/or outside walls of the fireplace.

Convection air routing / Heating chamber / Mounting surface

The fireplace, i.e. the heating insert and the additional reheating device (if present) with the heating gas pipe and connecting piece, is enclosed by an external casing or trim, which has to be assembled on site. The external casing consists of walls, bottom plate and top cover, which together form the so called heating chamber. Appropriate external casing materials -> see TROL.

Building surfaces can form parts of the external casing (mounting surfaces = e.g. floor area, ceiling area; adjacent wall = part of building wall which is in direct contact with the fireplace casing).

The heating chamber must be insulated from all mounting surfaces and adjacent walls (inactive casing surfaces). The necessary insulation thickness depends on the material of mounting surface and the mounting conditions (see "Building protection").

The distances between the stove components and the external casing create a convection space (31/36). Stream of air in this convection space helps to transfer some of the heat which is produced during combustion through the openings in external casing (circulating air/warm air) to the room of installation.

Convection casing

The convection casing (optional accessory) encloses the significant part of the heating insert and helps to transfer the most of hot air which is produced during combustion. Connections on the top of convection casing allow for transfer of this hot air by using dedicated air ducts. The convection casing does not include the hot air share produced by heating gas pipe, reheating systems and smoke pipe connecting piece.

Convection air ducts/shafts

All convection air ducts/shafts must be made of abrasion resistant, dimensionally stable and non-flammable materials; they must be tight and accessible for inspection and cleaning. Ducts and duct sections within the fireplace must be executed according to TROL specifications. Appropriate insulation must be provided where necessary. Construction law requirements regarding fire protection must be observed.

External casing / Active trim

The external casing (37) of the stove/fireplace insert is used to project heat into the room and must be made of non-flammable A1 class building materials according to DIN EN 13501-1. The casing must be stable for a lifetime of the fireplace. Vertical and inclined surfaces of the stove casing, made of mineral building materials, must not exceed **120°C** (surface temperature). Surfaces of the casing, where objects of any kind may be placed for decoration or where wood is held (wood stack), as well as casing walls made of other materials, cannot exceed **85°C** (surface temperature). Use thermal insulation, if necessary. The casing cannot be affixed at any point to the fireplace itself. Its construction must be self-supporting. Between the stove/fireplace insert and the external casing, as well as between the supporting frame and the casing, an expansion strap and/or sealing tape must be used to compensate the different expansions caused by high temperature.

Convection air supply

Hot air convection system: Fireplace with openings and/or warm air gratings in external casing

- Without convection casing
Room air (circulating air) enters at the bottom of fireplace into the heating chamber (42), it gets warm and returns to the room as convection air through the openings (41) provided in the upper part of the fireplace external casing. The necessary free cross section of the circulation air opening (42) and supply air opening (41) depends on the type of the additional reheating surface and mode of operation (see "Technical data"). Necessary insulation thickness for adjacent wall -> see Building protection.
- With convection casing
Room air (circulating air) enters at the bottom of fireplace into the heating chamber (42). The hot air produced inside the convection casing must be returned through dedicated openings. The hot air can be transferred by ducts or shafts, which are connected at the convection casing outlets.
The remaining heat produced by reheating systems, heating gas pipe, and smoke pipe connecting piece must be returned to the room through the openings (41) in the upper part of the external casing. The necessary free cross section of the circulation air opening (42) and warm air opening (41) depends on the type of the additional reheating surface and mode of operation (see "Technical data"). With convection casing, the adjacent wall insulation can be different than specified (see Assembly Instructions for convection casing).
- Fireplace without openings and/or warm air gratings in external casing (hypocaust principle)
Convection air is circulating inside a closed fireplace casing. Heat is projected through "active" walls of the fireplace. Thermal load is higher as when heat is returned into the room through warm air openings. This higher load must be taken into account by using appropriate additional thermal insulation (see "Technical data" or e.g. active air cooling). The dimensions and design of active trim must be adapted to the heating power of the heating device.

14 BUILDING PROTECTION

All building areas and (adjacent) walls which are in contact with the heating chamber must be protected against overheating. Fire protection and static considerations must be taken into account. From a static point of view, the admissible temperatures must be lower than specified by fire protection requirements.

Adjacent walls cannot be exposed to temperatures above 85°C (fire protection requirement). The same is valid for built-in furniture. Required insulation measures depend on the type and design of the surface. The load bearing capacity of the mounting surface must be checked; appropriate means for load distribution must be taken if necessary.

Heat insulation

Heat insulation layers (32/44/46/54) must be laid smoothly and overlapping. The surface must be clean and resistant to abrasion. Their planned position must be permanently stable and durable. Insulation layers from abrasive materials must have an appropriate covering (for example, using steel panels). Only approved insulation materials must be used (see "Approved insulation materials"). The insulation thicknesses specified in Technical Data for flammable materials or other materials including flammable components are valid only for components with a heat transfer coefficient (U value) $\geq 0,4\text{W/m}^2\text{K}$. For U value $< 0,4\text{W/m}^2\text{K}$, additional measures for thermal insulation must be taken (see DIN 18896:2013-12).

Protection of building walls

There are two types of building walls: "protected walls" and (other) "adjacent walls". For protected walls, a thermal insulation layer (32) and a brick lining (33) must be used. The brick lining must reach up to the insulation of ceiling or to the height of external casing, and must extend at least **20 cm (7.87 in)** above the smoke pipe connecting piece (39).

- **protected walls are** Walls from flammable materials or containing flammable materials, and all walls with flammable objects behind them (e.g. built-in furniture, wooden panels).

- **other walls** (35), these are: Walls from mineral building materials, such as aerated concrete, bricks, sand-lime bricks, with thickness of more than **10 cm (3.94 in)**. For these walls, the insulation layer (32) is enough; a brick lining (33) is not necessary.

Protection of ceiling above the fireplace

If the stove casing reaches up to the ceiling (43), it must be protected by a sufficient insulation layer (44), if only the ceiling is made from flammable materials or includes supporting elements of the building structure.

Floor protection

Floors without sufficient load distribution must be provided with a reinforced concrete slab (45) of at least 6 cm (2.36 in) thickness. The mounting surface must be protected against excessive temperatures by sufficient insulation layer (46).

Firewood storage

The surface temperature of the walls surrounding a recessed firewood storage must not exceed **85 °C**. This must be ensured by appropriate construction or insulation of walls.

Warm air vents/gratings

Warm air vents (41) must be situated at least 50 cm (19.69 in) below ceiling level and 30 cm (11.81 in) away from lateral built-in furniture, flammable materials or supporting concrete walls. Air gratings or vents must be located possibly high, to prevent heat accumulation within the external fireplace casing. Air gratings or vents must allow for easy cleaning. The required unobstructed area of air gratings depends on the type of reheating device. The air gratings or air vents must be arranged to avoid clogging up.

Active air cooling

Active air cooling is a permanently open, non-closing shaft, gap or empty space, where part of the heat projected by the fireplace is dissipated by convection to protect the building or flammable components in adjacent walls or mounting surface.

Decorative beam over fireplace door

Decorative beams (52) are allowed with **1 cm** clearance between the beam and the wall of the fireplace casing (37), only outside the heat radiation range. The clearance must not allow for heat accumulation between the beam and the fireplace wall. Decorative beams cannot be parts of the building structure.

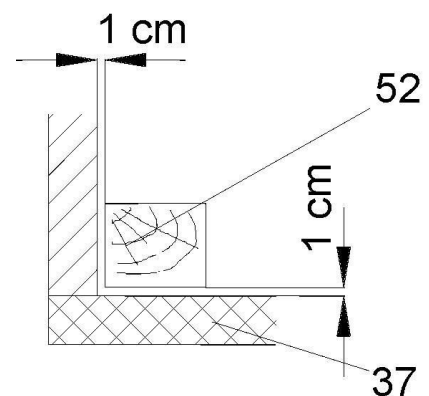

Floor before fireplace door

Floors from flammable materials must be protected by a cover (47) from non-flammable materials or replaced by non-flammable materials with the following dimensions:

- in front of the fireplace = at least **50 cm (19.69 in)**
- on both sides of the fireplace = at least **30 cm (11.81 in)**

above the fireplace door opening

Within heat radiation range of the fireplace

Structures from flammable building materials or including flammable components (48), as well as built-in furniture (49) must be separated from the combustion chamber opening in front, to the sides and above the fireplace by at least **80 cm** air clearance. When the combustion chamber door is designed without a "window with integrated heat protection", the radiation area is maintained with a minimum distance of 55 cm. If these parts are protected by a heat protecting screen cooled by air on both sides, a distance of 40 cm must be kept.

Outside the heat radiation range

Structures from flammable materials (48) or with flammable components, as well as built-in furniture (49) must have at least **5 cm** air clearance to the outside walls of the fireplace. In this clearance, the room air must be able to circulate without any obstacles. Heat accumulation must be avoided. Structures covering only small areas of the fireplace casing walls, like flooring, adjoining wall coverings and insulation layers on ceiling and building walls, can be led right up to the fireplace casing.

Electric lines

Mounting surface must be free from typical electrical wiring, unless it is protected by special measures against permanent influence of temperatures >30°C (86°F). Special wiring with higher heat resistance is permitted (see TROL).

15 APPROVED INSULATION MATERIALS

Thermal insulation materials used must fulfil the following requirements according to AGI-Q 132 standard:

Material:	Group 12, 13	Rock wool or slag wool
Delivered as:	Group 06, 07, 08	slabs, stitched mats or shells
Thermal conductivity:	Group 01 - 21	
Upper temperature limit:	Group 70 - 76	equivalent to 700 °C - 760 °C
Nominal density kg/m ³ :	Group 08 - 18	equivalent to 80 kg/m ³ - 180 kg/m ³

Thermal insulation materials used must be at least equivalent to class A1 building materials according to DIN 4102, Part 1. The temperature limit for use must exceed 700°C and the density must be greater than 80 kg/m³ for these materials. The insulation material rating (heat index) must be known. In addition, insulation materials inside convection space must be abrasion-resistant and covered with non-reflecting material. Instead of brick lining and insulation materials according to AGI-Q 132, any other insulation materials approved for the given purpose by DIBt (Deutsches Institut für Bautechnik) might be used. For necessary insulation thicknesses please refer to the manufacturer's specifications.

Insulation material rating for mineral wool according to AGI Worksheet Q 132:

Insulation materials		Delivered as		Thermal conductivity		Upper temperature limit		Nominal density	
Gr.	Type	Gr.	Form	Gr.	Delivered as	Gr.	°C	Gr.	kg/m ³
11	Glass wool	04	Felts	01	Mats, stitched, Limit 1	10	100	02	20
12	Rock wool	05	Lamella mats		Mats, stitched, Limit 2	12	120	03	30
13	Slag wool	06	Mats, stitched	02	Shells, Limit 1	14	140	04	40
			Slabs	10	Shells, Limit 2	16	160	05	50
		07	Shells	11	Slabs, Limit 1	.	.	06	60
		08	Segments	20	Slabs, Limit 2
		09	Braids	21	*)	72	720	.	.
		10	Panels	99		74	740	18	180
		11				76	760	99	**)

*) 99 is valid only for delivery forms in column 2, which have no declared limits.

***) 99 is valid only for shells.

Dimension sheets - Architektur 38/86

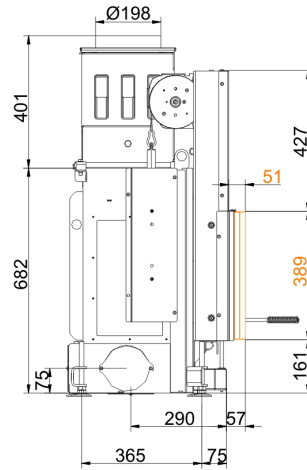
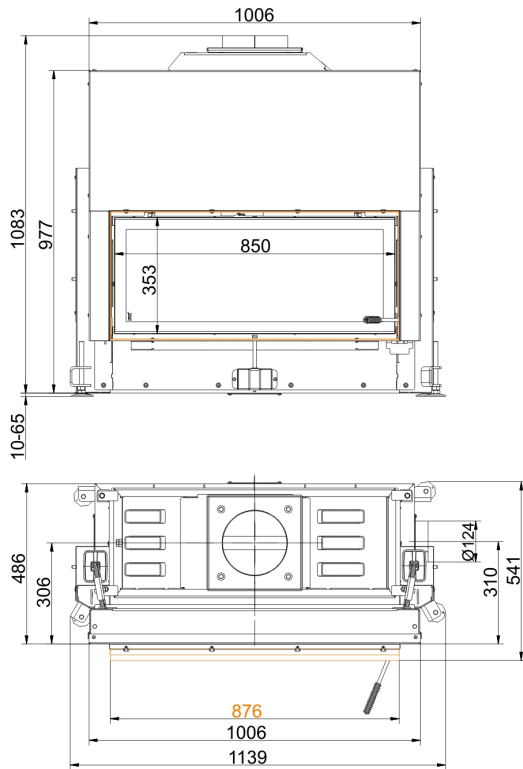

... with mounting frame 50 mm

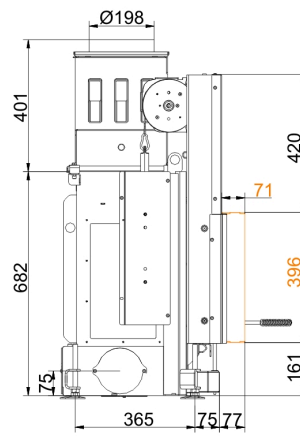
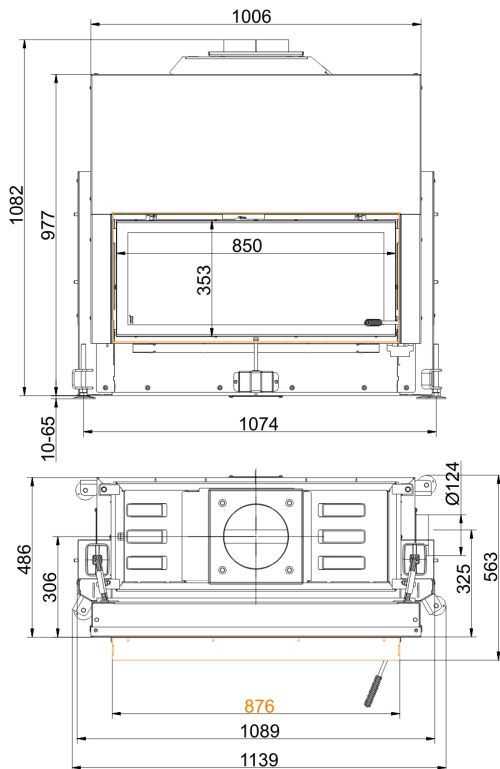

... with mounting frame 70 mm

Dimension sheets - Architektur 38/86

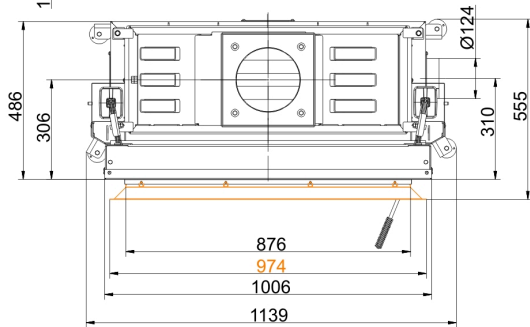
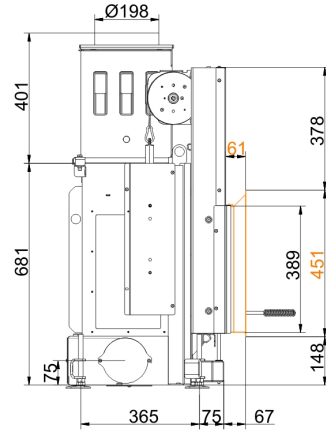
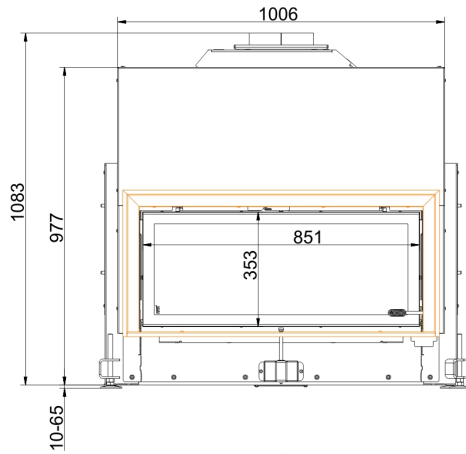

... with door frame

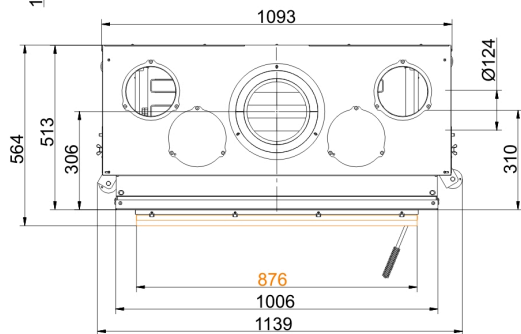
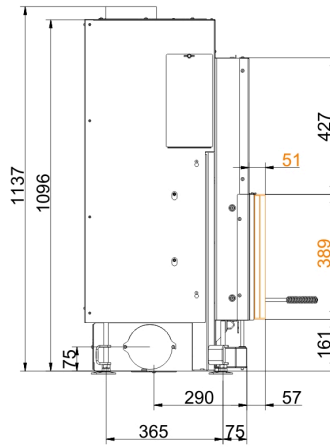
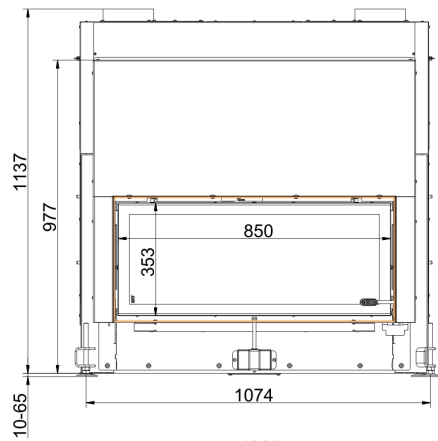

... with mounting frame 50 mm and convectional air coating

Dimension sheets - Architektur 38/86

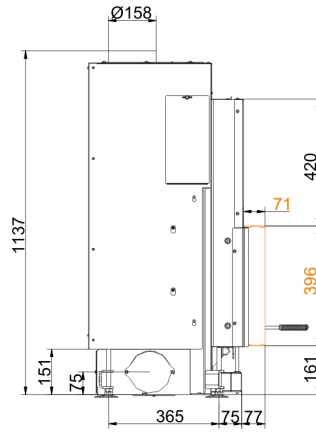
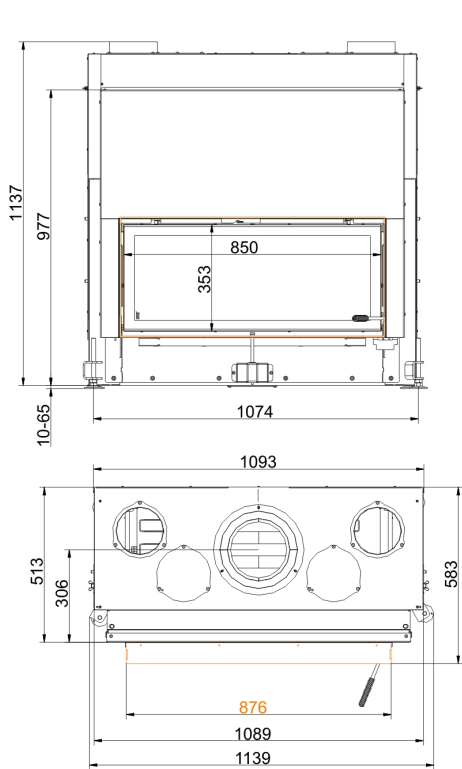

... with mounting frame 70 mm and convection cladding

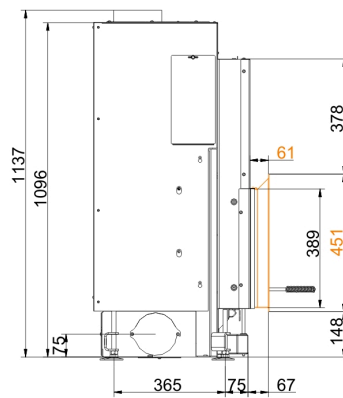
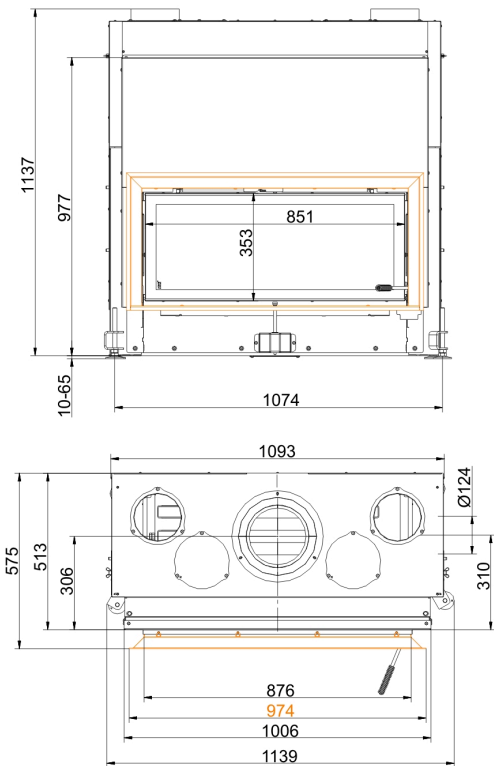

... with frame and convection cladding

We suggest for CAD planning Palette CAD. Permanent updated drawings: www.brunner.de
 Frames/ flue gas outlet connection/ combustion air supply connection/ front variants/ support bearing are marked in color.

Planning and installation - Architektur 38/86

Tested according to		EN 13229 W	EN 13229 WA
Values measured at		Rated power ¹⁾	Storage operation ²⁾
Suitable for all construction types according to rules		OK	OK
Data for functional demonstration			
Rated heat power	kW	10	-
Fire wood volume	kg/h	3.1	5.3
Combustion performance	kW	13.5	22
Flue gas mass flow	g/s	11	20
Outlet temperature (before reheating surface)	°C	-	375
Flue gas temperature after:			
metallic hot air hood	°C	240	-
1 x adjoining cast iron radiator (GNF 8/10)	°C	-	180
2 m ceramic accumulator ³⁾	°C	-	180
1,4 m accumulation stones (MSS) ³⁾	°C	-	180
Necessary supply pressure	Pa	12	15
Combustion air consumption	m ³ /h	30	45
Combustion air connection Ø	mm	125	125
Heating gas temperature (before the hood/dome variant)			
Rauchsammler	°C	-	375
Heat distribution			
Insert / reheating surface	%	30 / 30	30 / 30
Glass pane (single / double)	%	40 / -	40 / -
Cross-section of gratings ⁴⁾			
Convection air	cm ²	700 / 100 / 500	700 / 100 / 500
Supply air	cm ²	700 / 100 / 500	700 / 100 / 500
Minimal oven surface for closed construction type			
Heat dissipating surface	m ²	5	5
Minimal distances of the fireplace			
to cladding, insulation layer	cm	6	6
to mounting floor	cm	2	2
Thermal insulation without / with air gratings ⁵⁾			
Mounting wall	cm	18 / 14	18 / 14
Floor	cm	2	2
Ceiling	cm	28 / 20	28 / 20
Brick lining for combustible wall	cm	10	10
Weight			
Fireplace / combustion chamber	kg	160 / 64 / -	
Meets requirement/limit values for:			
Germany/ Austria / Switzerland / Norway		1.BImSchV (Stufe 2) / 15a BVG (2015) / LRV / NS 3059	

- 1) Indications to "Rated power" determined with metallic reheating surface
- 2) Indications to "Storage operation" for the manual execution of the reheating surface (guide values).
- 3) Standard value or calculated functional proof required.
- 4) for fireplace inserts / flue gas pipe / metallic reheating surface
- 5) Values determined with upper air cross-sections; stove cladding is heat emitting.

Dimension sheets - Architektur-Kamin Tunnel 38/86

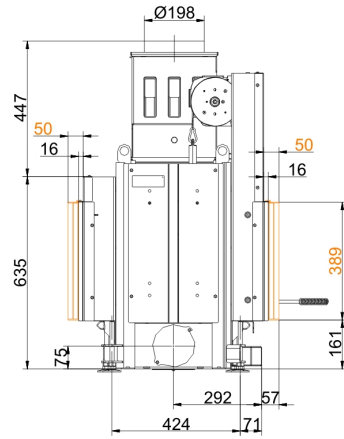
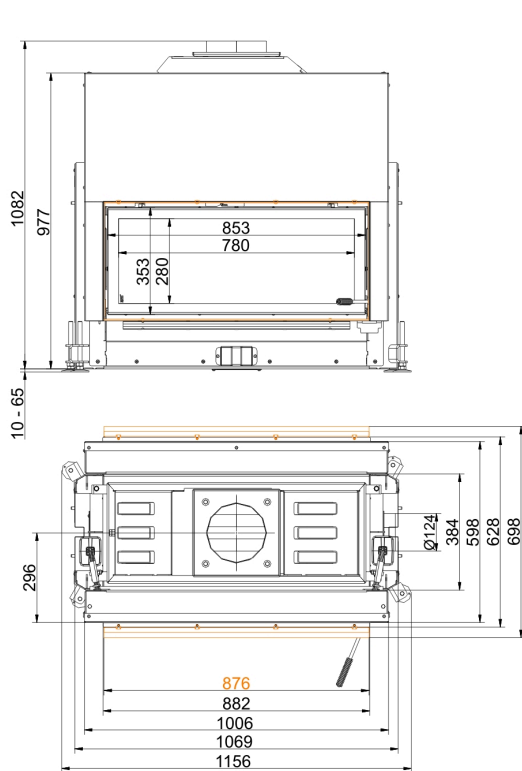

... /tilting door with mounting frame 50 mm

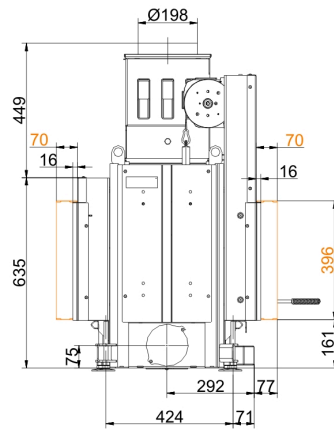
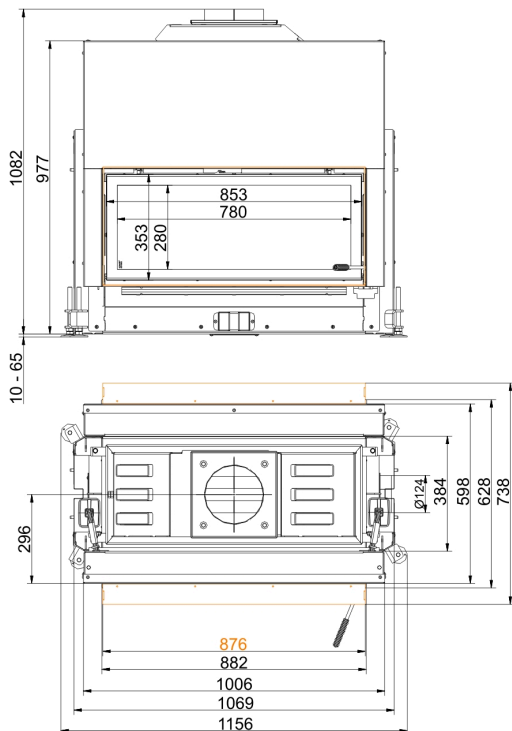

... /tilting door with mounting frame 70 mm

Dimension sheets - Architektur-Kamin Tunnel 38/86

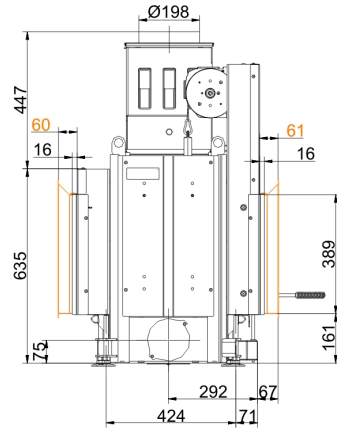
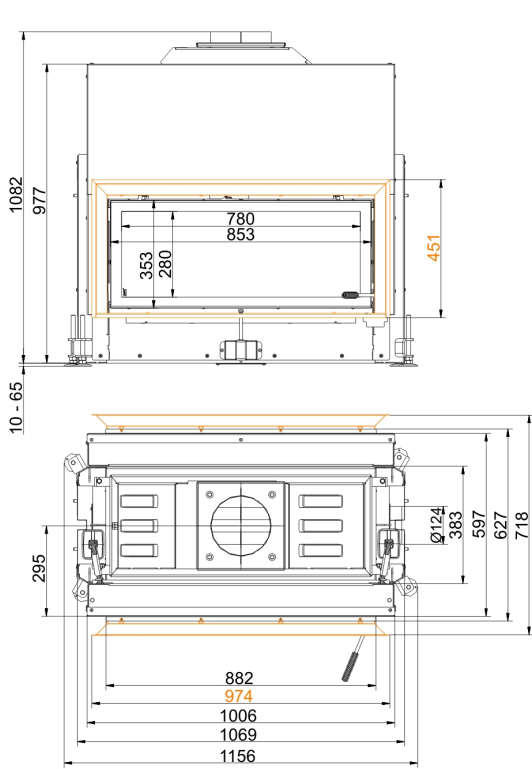

... /tilting door with door frame

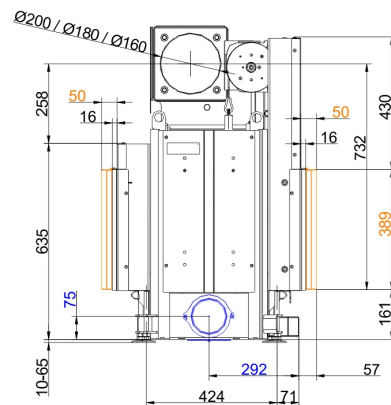
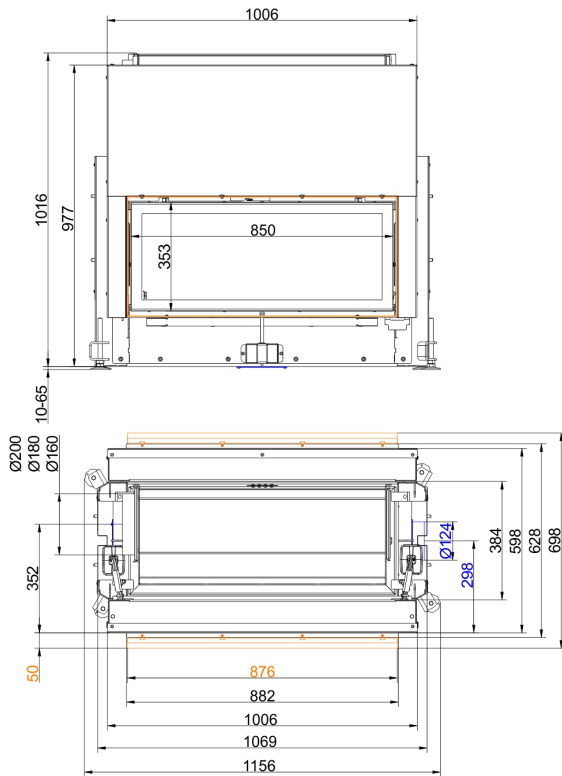

... with mounting frame 50 mm

Dimension sheets - Architektur-Kamin Tunnel 38/86

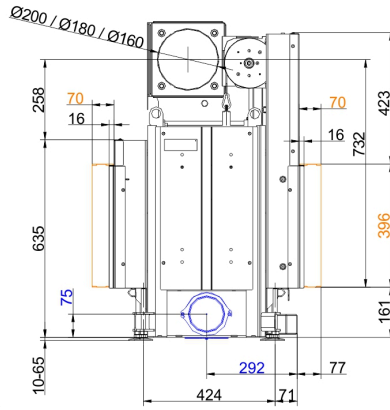
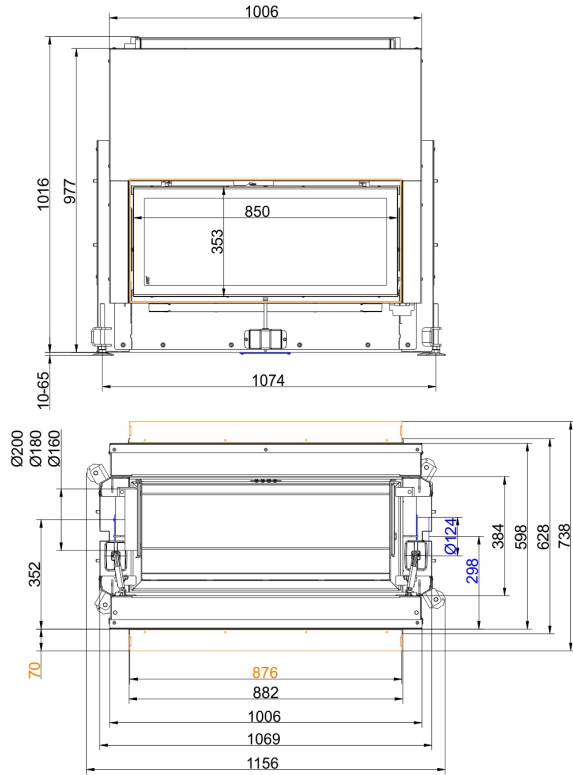

... with mounting frame 70 mm

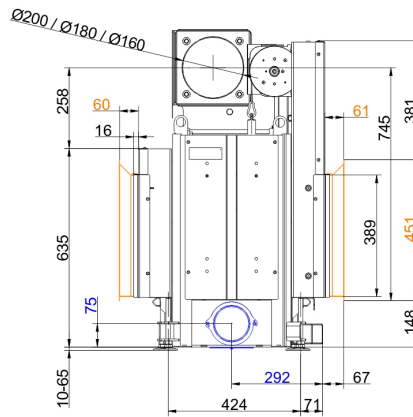
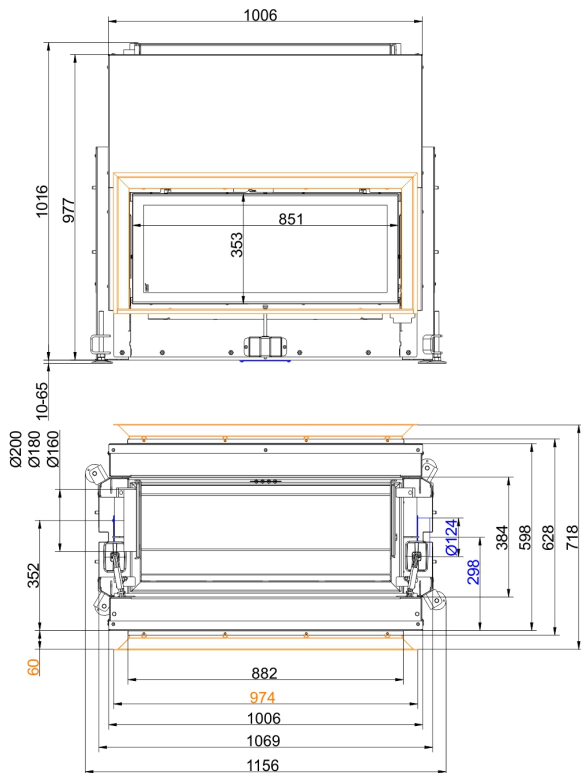

... with door frame

Dimension sheets - Architektur-Kamin Tunnel 38/86

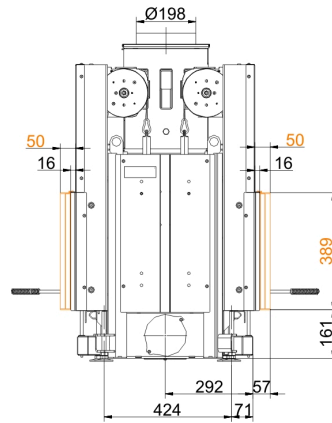
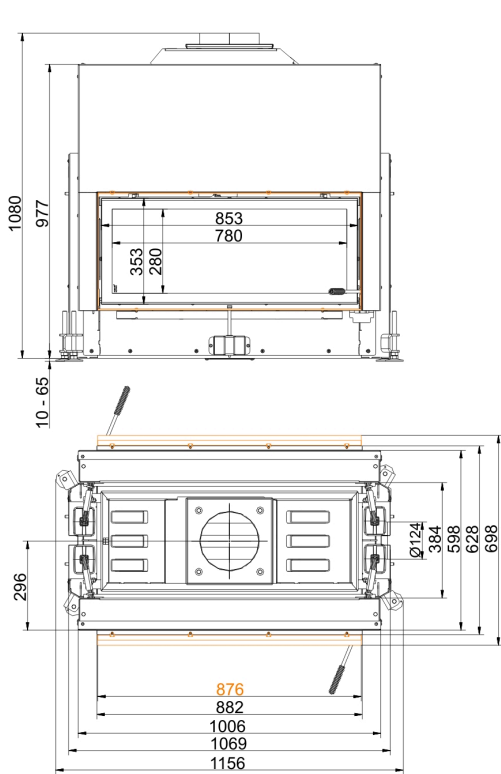

... with mounting frame 50 mm

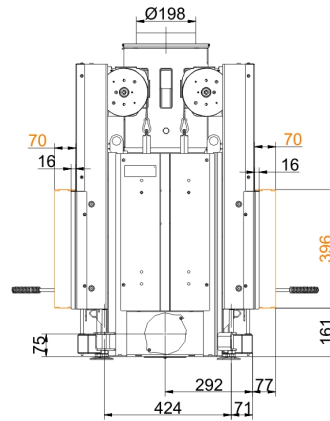
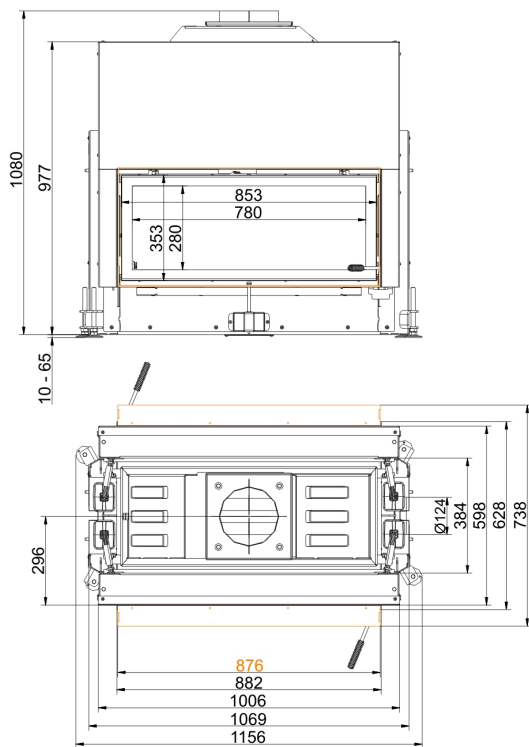

... with mounting frame 70 mm

Dimension sheets - Architektur-Kamin Tunnel 38/86

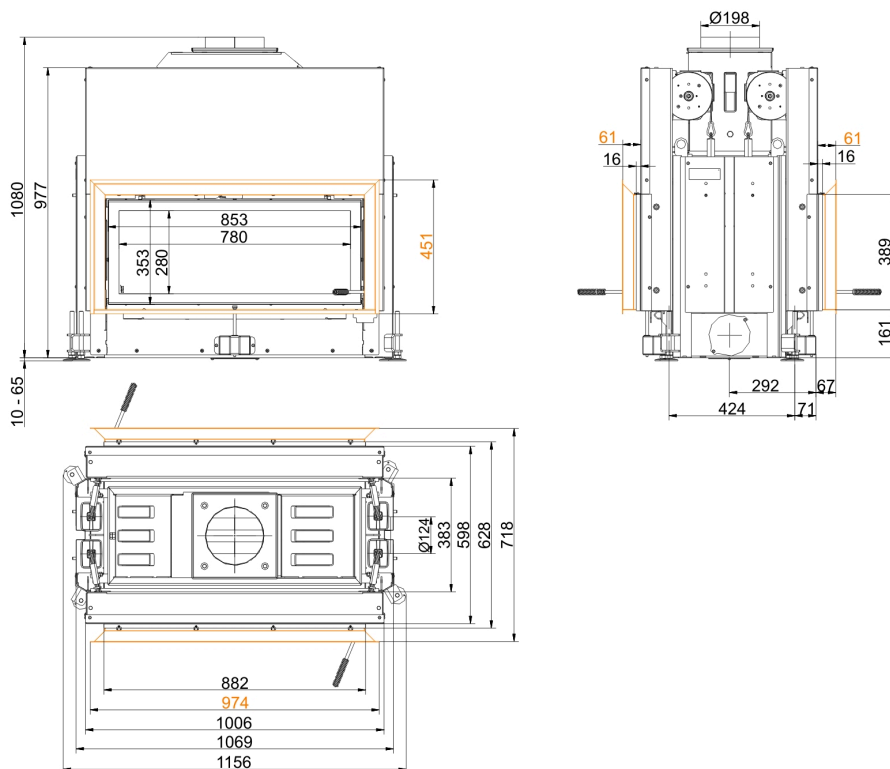

... with door frame

We suggest for CAD planning Palette CAD. Permanent updated drawings: www.brunner.de
 Frames/ flue gas outlet connection/ combustion air supply connection/ front variants/ support bearing are marked in color.

Planning and installation - Architektur-Kamin Tunnel 38/86

Tested according to		EN 13229 W
Values measured at		Rated power ¹⁾
Suitable for all construction types according to rules		OK
Data for functional demonstration		
Rated heat power	kW	10
Fire wood volume	kg/h	3.1
Combustion performance	kW	13.5
Flue gas mass flow	g/s	11
Flue gas temperature after:		
metallic hot air hood	°C	220
Necessary supply pressure	Pa	12
Combustion air consumption	m ³ /h	30
Combustion air connection Ø	mm	125
Heat distribution		
Insert / reheating surface	%	50 / -
Glass pane (single / double)	%	50 / -
Cross-section of gratings ²⁾		
Convection air	cm ²	700 / 100 / -
Supply air	cm ²	700 / 100 / -
Minimal oven surface for closed construction type		
Heat dissipating surface	m ²	3
Minimal distances of the fireplace		
to cladding, insulation layer	cm	6
to mounting floor	cm	2
Thermal insulation without / with air gratings ³⁾		
Mounting wall	cm	18 / 14
Floor	cm	2
Ceiling	cm	28 / 20
Brick lining for combustible wall	cm	10
Weight		
Fireplace / combustion chamber	kg	200 / 51 / -
Meets requirement/limit values for:		
Germany/ Austria / Switzerland / Norway		1.BImSchV (Stufe 2) / 15a BvG (2015) / LRV / -

- 1) Indications to "Rated power" determined with metallic reheating surface
- 2) for fireplace inserts / flue gas pipe / metallic reheating surface
- 3) Values determined with upper air cross-sections; stove cladding is heat emitting.

Dimension sheets - Architektur 45/101 lifting door

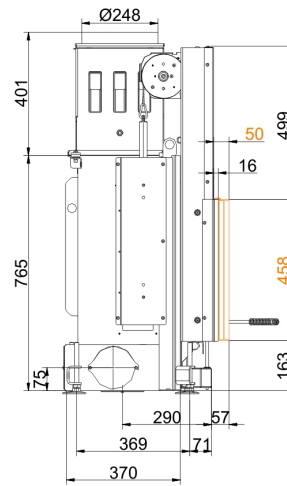
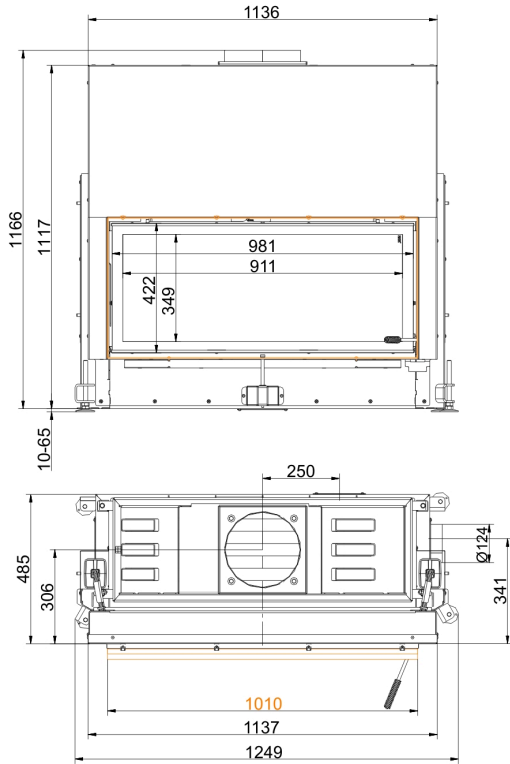

... with mounting frame 50 mm

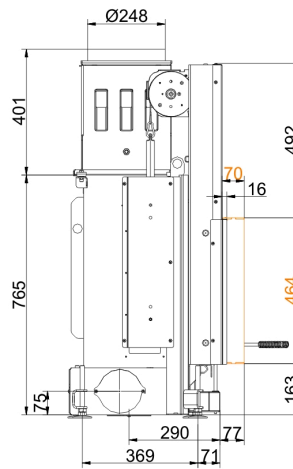
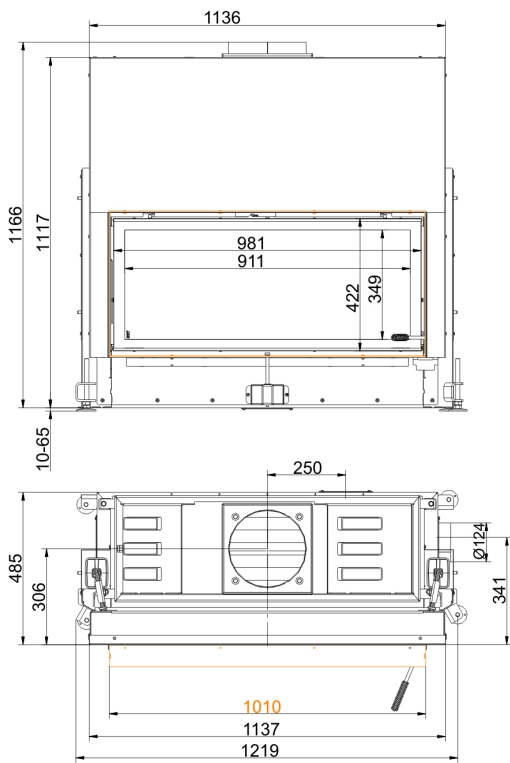

... with mounting frame 70 mm

Dimension sheets - Architektur 45/101 lifting door

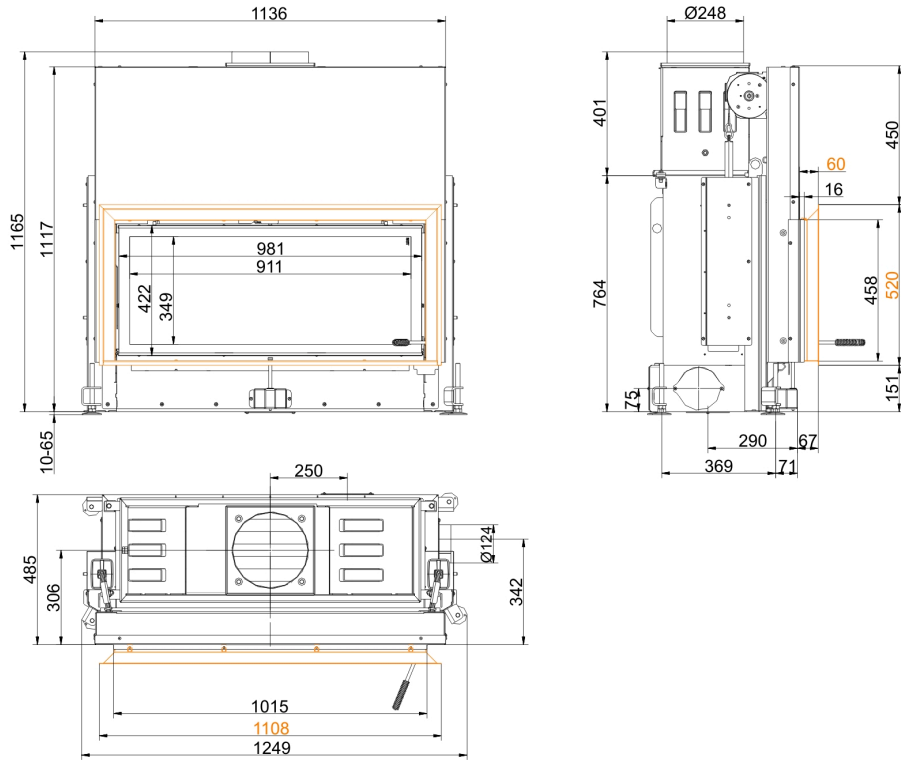

... with door frame

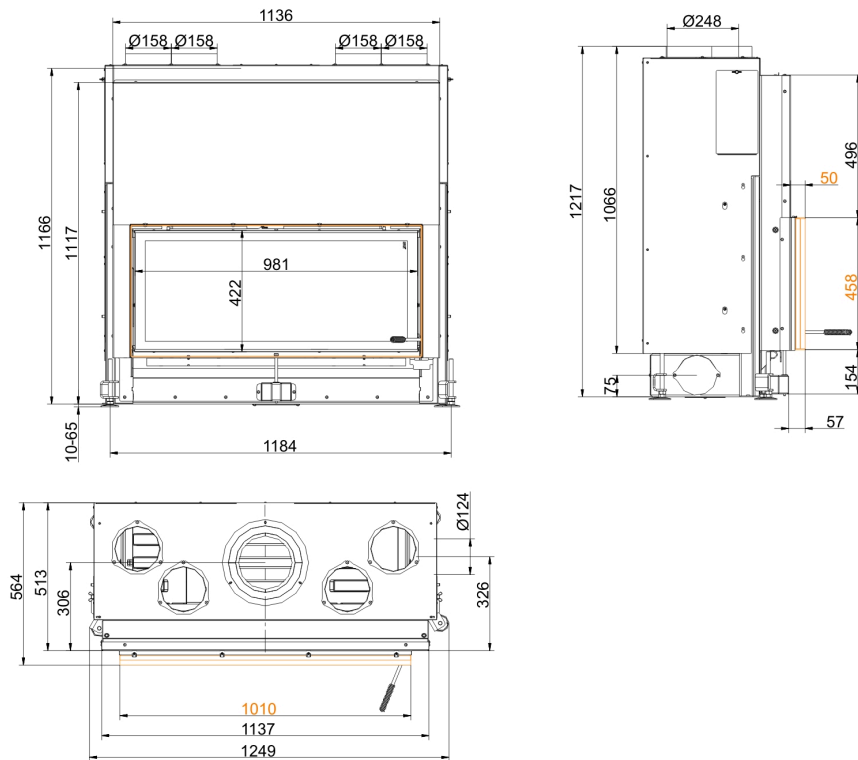

... with mounting frame 50 mm and convectional air coating

Dimension sheets - Architektur 45/101 lifting door

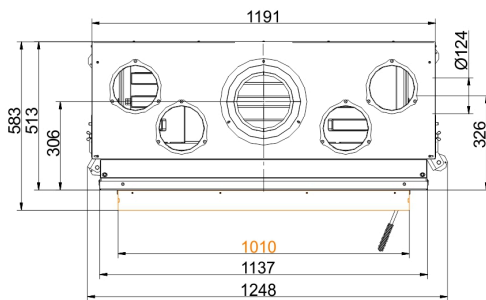
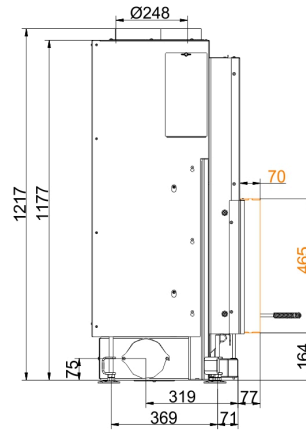
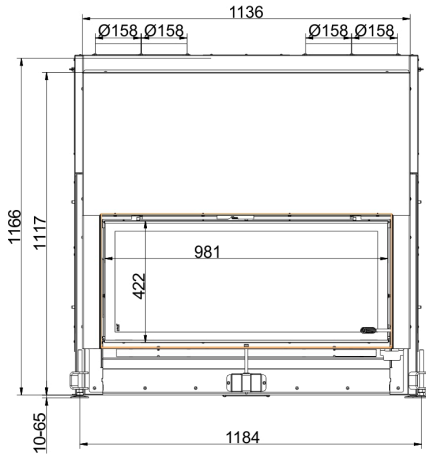

... with mounting frame 70 mm and convection cladding

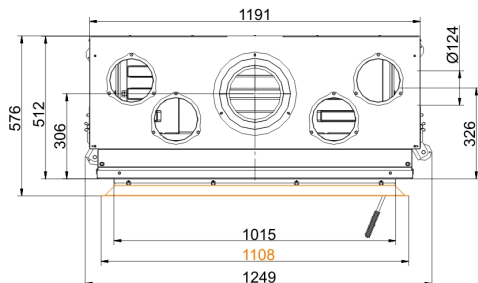
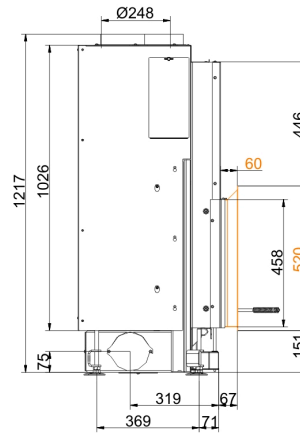
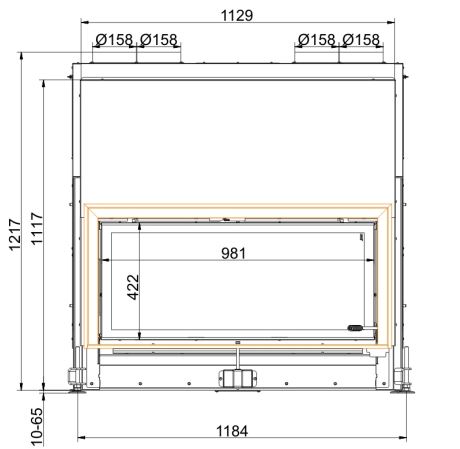

... with frame and convection cladding

We suggest for CAD planning Palette CAD. Permanent updated drawings: www.brunner.de
 Frames/ flue gas outlet connection/ combustion air supply connection/ front variants/ support bearing are marked in color.

Planning and installation - Architektur 45/101 lifting door

Tested according to		EN 13229 W
Values measured at		Rated power ¹⁾
Suitable for all construction types according to rules		OK
Data for functional demonstration		
Rated heat power	kW	14
Fire wood volume	kg/h	4.3
Combustion performance	kW	18
Flue gas mass flow	g/s	16
Flue gas temperature after:		
metallic hot air hood	°C	220
Necessary supply pressure	Pa	12
Combustion air consumption	m ³ /h	40
Combustion air connection Ø	mm	125
Heat distribution		
Insert / reheating surface	%	60 / -
Glass pane (single / double)	%	40 / -
Cross-section of gratings ²⁾		
Convection air	cm ²	900 / 100 / -
Supply air	cm ²	900 / 100 / -
Minimal oven surface for closed construction type		
Heat dissipating surface	m ²	7.2
Minimal distances of the fireplace		
to cladding, insulation layer	cm	6
to mounting floor	cm	2
Thermal insulation without / with air gratings ³⁾		
Mounting wall	cm	18 / 14
Floor	cm	4 / 2
Ceiling	cm	25 / 18
Brick lining for combustible wall	cm	10
Weight		
Fireplace / combustion chamber	kg	200 / 80
Meets requirement/limit values for:		
Germany/ Austria / Switzerland / Norway		1.BImSchV (Stufe 2) / 15a BVG (2015) / LRV / NS 3059

- 1) Indications to "Rated power" determined with metallic reheating surface
- 2) for fireplace inserts / flue gas pipe / metallic reheating surface
- 3) Values determined with upper air cross-sections; stove cladding is heat emitting.

Dimension sheets - Architektur-Tunnel 45/101 lifting door

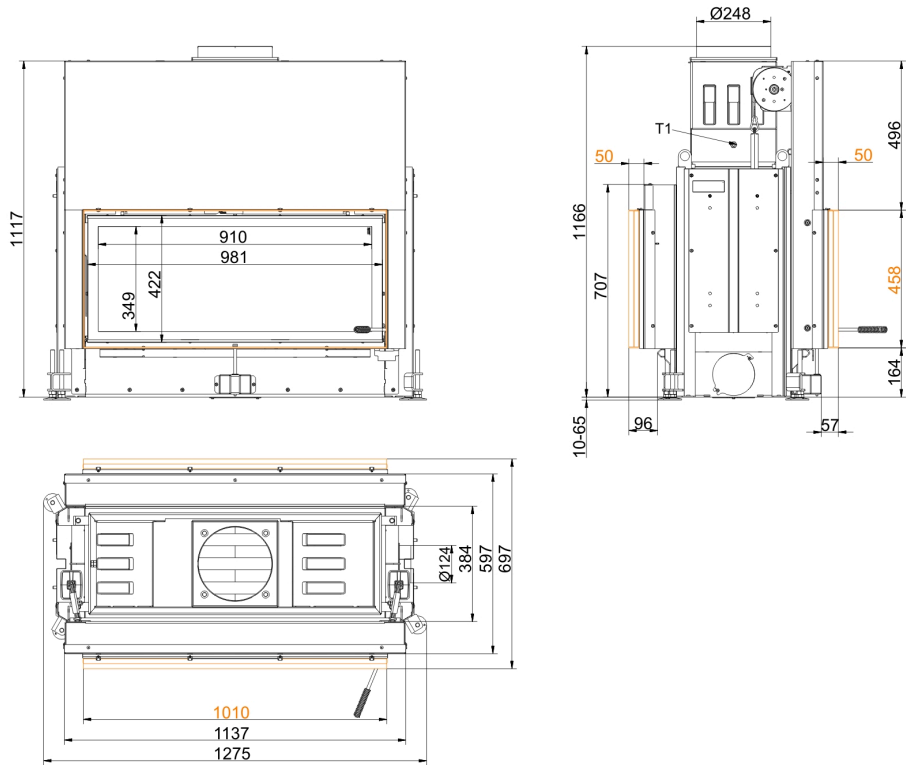

... /tilting door with mounting frame 50 mm

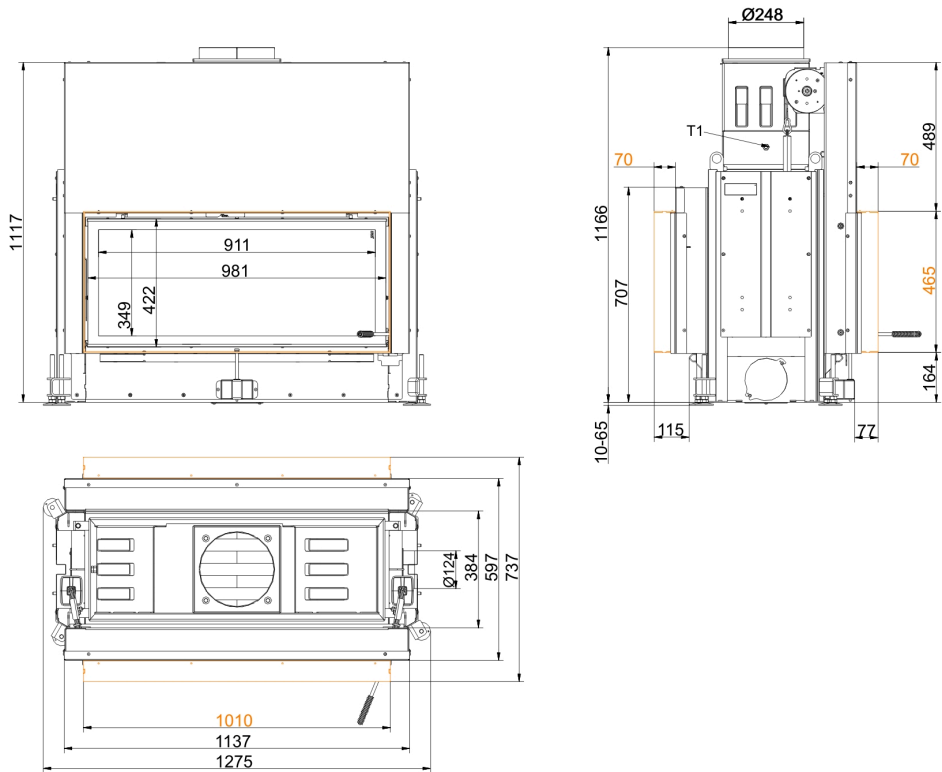

... /tilting door with mounting frame 70 mm

Dimension sheets - Architektur-Tunnel 45/101 lifting door

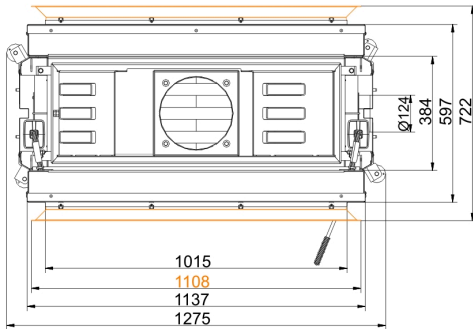
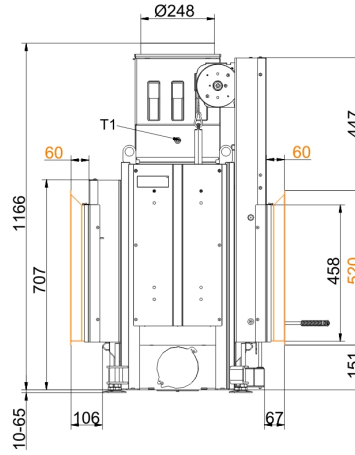
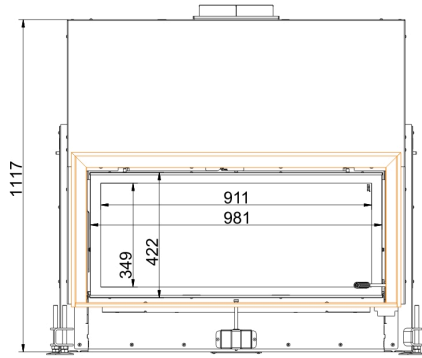

... /tilting door with door frame

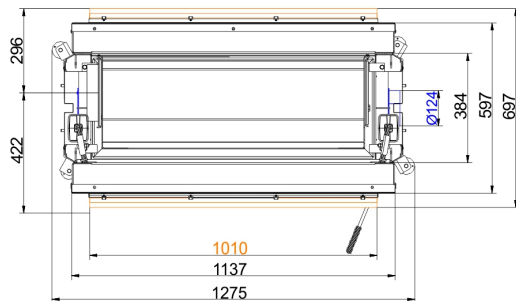
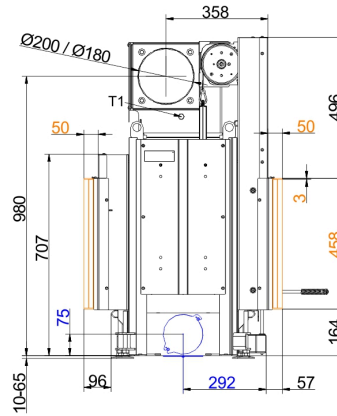
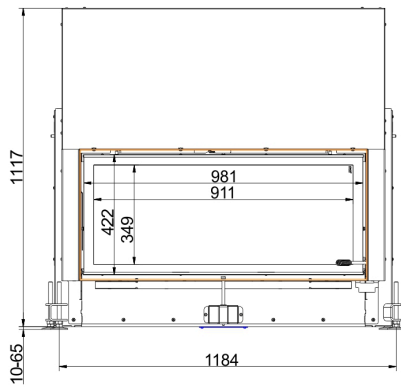

... with mounting frame 50 mm

Dimension sheets - Architektur-Tunnel 45/101 lifting door

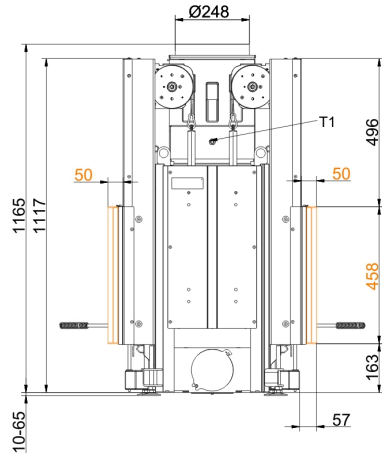
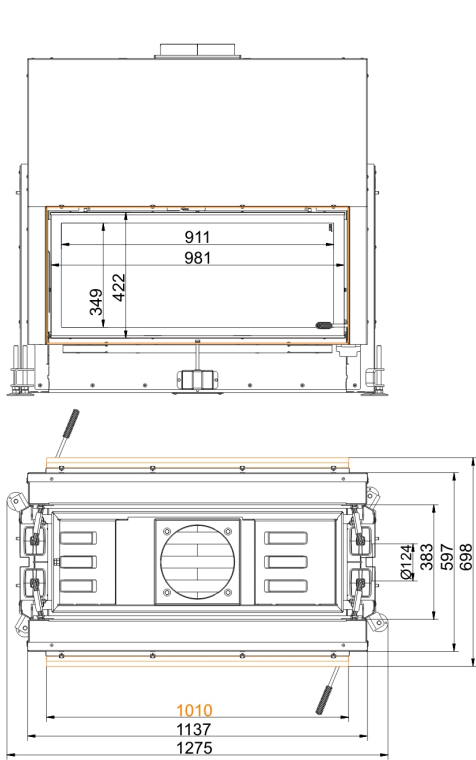

... with mounting frame 50 mm

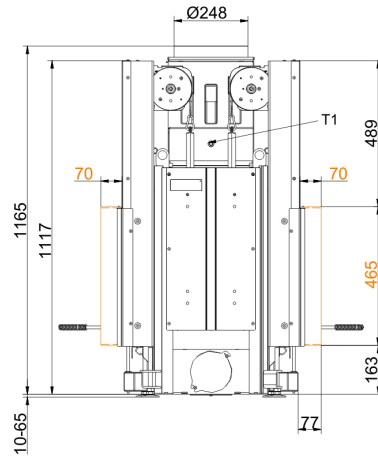
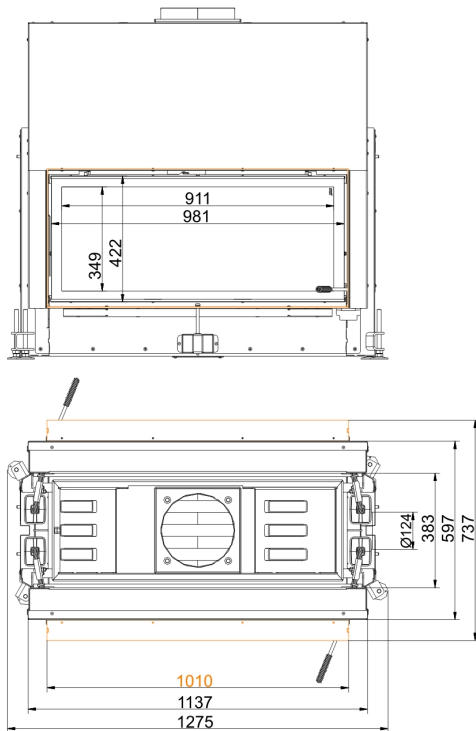

... with mounting frame 70 mm

Dimension sheets - Architektur-Tunnel 45/101 lifting door

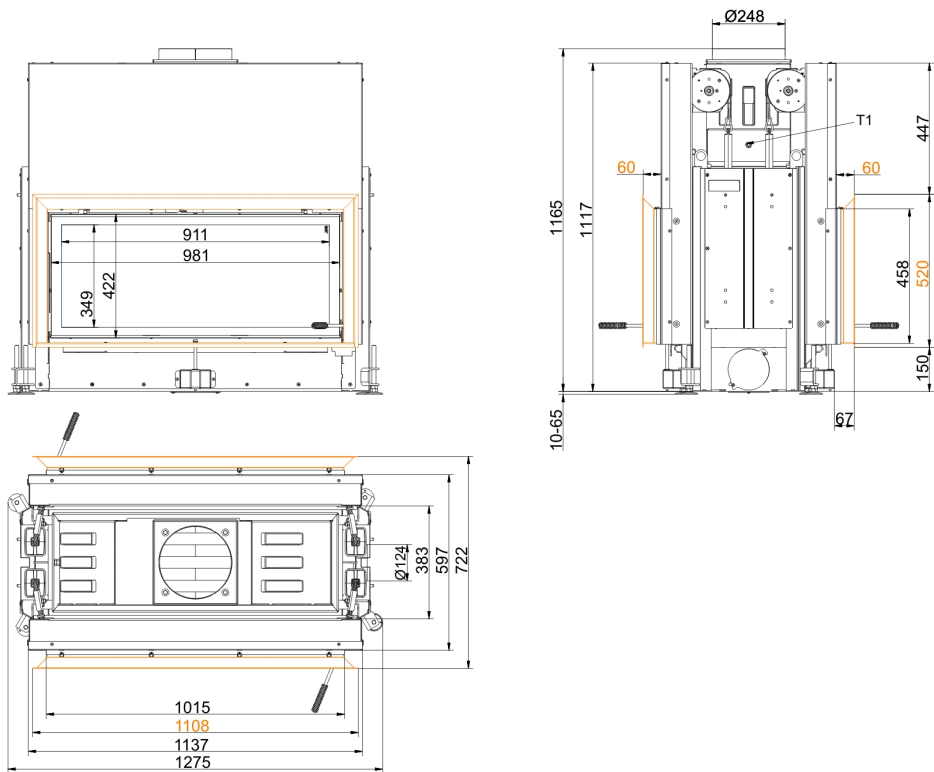

... with door frame

We suggest for CAD planning Palette CAD. Permanent updated drawings: www.brunner.de
 Frames/ flue gas outlet connection/ combustion air supply connection/ front variants/ support bearing are marked in color.

Planning and installation - Architektur-Tunnel 45/101 lifting door

Tested according to		EN 13229 W
Values measured at		Rated power ¹⁾
Suitable for all construction types according to rules		OK
Data for functional demonstration		
Rated heat power	kW	14
Fire wood volume	kg/h	4.3
Combustion performance	kW	18
Flue gas mass flow	g/s	16
Flue gas temperature after:		
metallic hot air hood	°C	205
Necessary supply pressure	Pa	12
Combustion air consumption	m ³ /h	40
Combustion air connection Ø	mm	125
Heat distribution		
Insert / reheating surface	%	50 / -
Glass pane (single / double)	%	50 / -
Cross-section of gratings ²⁾		
Convection air	cm ²	800 / 100 / -
Supply air	cm ²	800 / 100 / -
Minimal oven surface for closed construction type		
Heat dissipating surface	m ²	4.8
Minimal distances of the fireplace		
to cladding, insulation layer	cm	6
to mounting floor	cm	2
Thermal insulation without / with air gratings ³⁾		
Mounting wall	cm	18 / 12
Floor	cm	4 / 2
Ceiling	cm	25 / 18
Brick lining for combustible wall	cm	10
Weight		
Fireplace / combustion chamber ⁴⁾	kg	(231 + 39) / 59
Meets requirement/limit values for:		
Germany/ Austria / Switzerland / Norway		1.BImSchV (Stufe 2) / 15a BvG (2015) / LRV / -

- 1) Indications to "Rated power" determined with metallic reheating surface
- 2) for fireplace inserts / flue gas pipe / metallic reheating surface
- 3) Values determined with upper air cross-sections; stove cladding is heat emitting.
- 4) Fireplace insert = body + top mounted exchanger

Dimension sheets - Architektur 53/121 lifting door

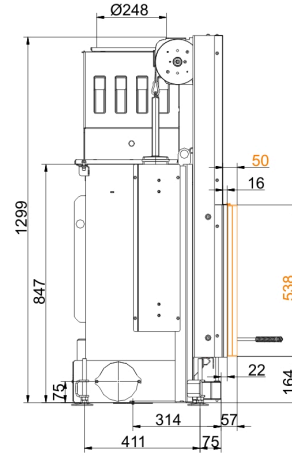
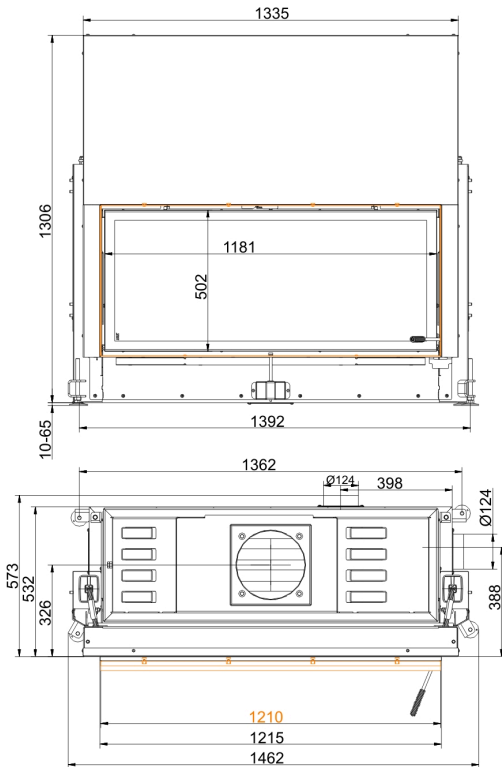

... with mounting frame 50 mm

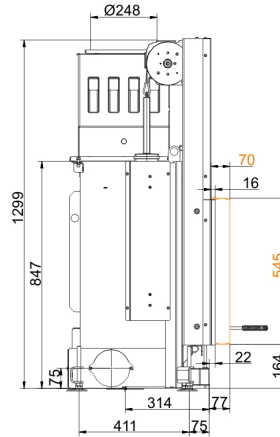
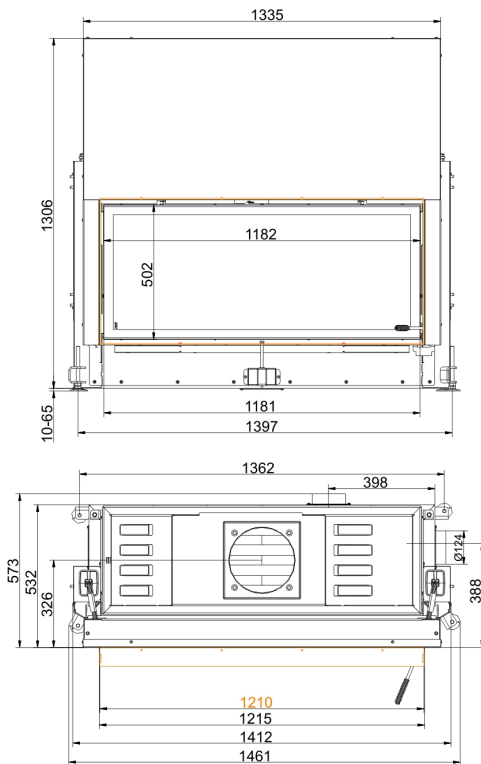

... with mounting frame 70 mm

Dimension sheets - Architektur 53/121 lifting door

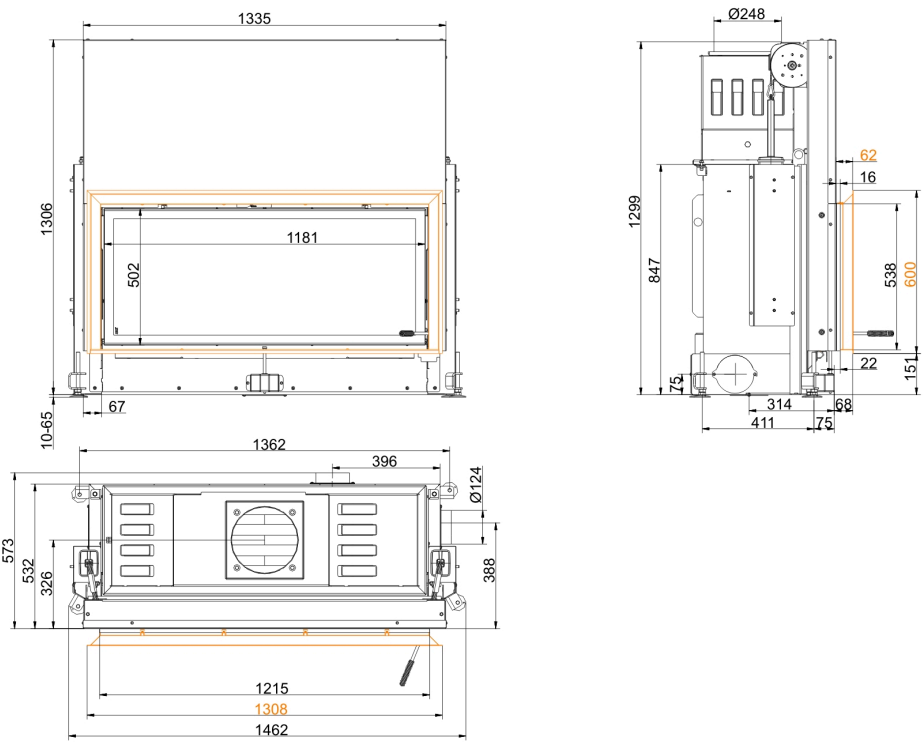

... with door frame

We suggest for CAD planning Palette CAD. Permanent updated drawings: www.brunner.de
 Frames/ flue gas outlet connection/ combustion air supply connection/ front variants/ support bearing are marked in color.

Planning and installation - Architektur 53/121 lifting door

Tested according to		EN 13229 W
Values measured at		Rated power ¹⁾
Suitable for all construction types according to rules		OK
Data for functional demonstration		
Rated heat power	kW	13.5
Fire wood volume	kg/h	4.3
Combustion performance	kW	17
Flue gas mass flow	g/s	12
Flue gas temperature after:		
metallic hot air hood	°C	210
Necessary supply pressure	Pa	12
Combustion air consumption	m ³ /h	45
Combustion air connection Ø	mm	125
Heat distribution		
Insert / reheating surface	%	60 / -
Glass pane (single / double)	%	40 / -
Cross-section of gratings ²⁾		
Convection air	cm ²	800 / 100 / -
Supply air	cm ²	800 / 100 / -
Minimal oven surface for closed construction type		
Heat dissipating surface	m ²	7.2
Minimal distances of the fireplace		
to cladding, insulation layer	cm	6
to mounting floor	cm	2
Thermal insulation without / with air gratings ³⁾		
Mounting wall	cm	16 / 12
Floor	cm	4 / 2
Ceiling	cm	22 / 16
Brick lining for combustible wall	cm	10
Weight		
Fireplace / combustion chamber	kg	304 / 116
Meets requirement/limit values for:		
Germany/ Austria / Switzerland / Norway		1.BImSchV (Stufe 2) / 15a BVG (2015) / LRV / NS 3059

- 1) Indications to "Rated power" determined with metallic reheating surface
- 2) for fireplace inserts / flue gas pipe / metallic reheating surface
- 3) Values determined with upper air cross-sections; stove cladding is heat emitting.

Dimension sheets - Architektur-Tunnel 53/121

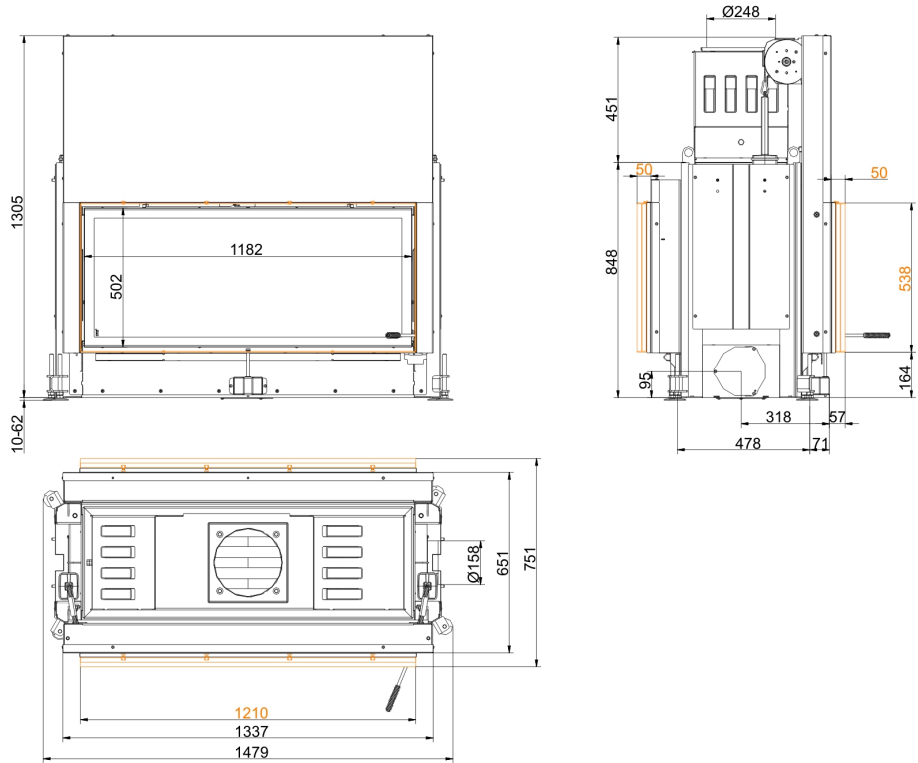

... /tilting door with mounting frame 50 mm

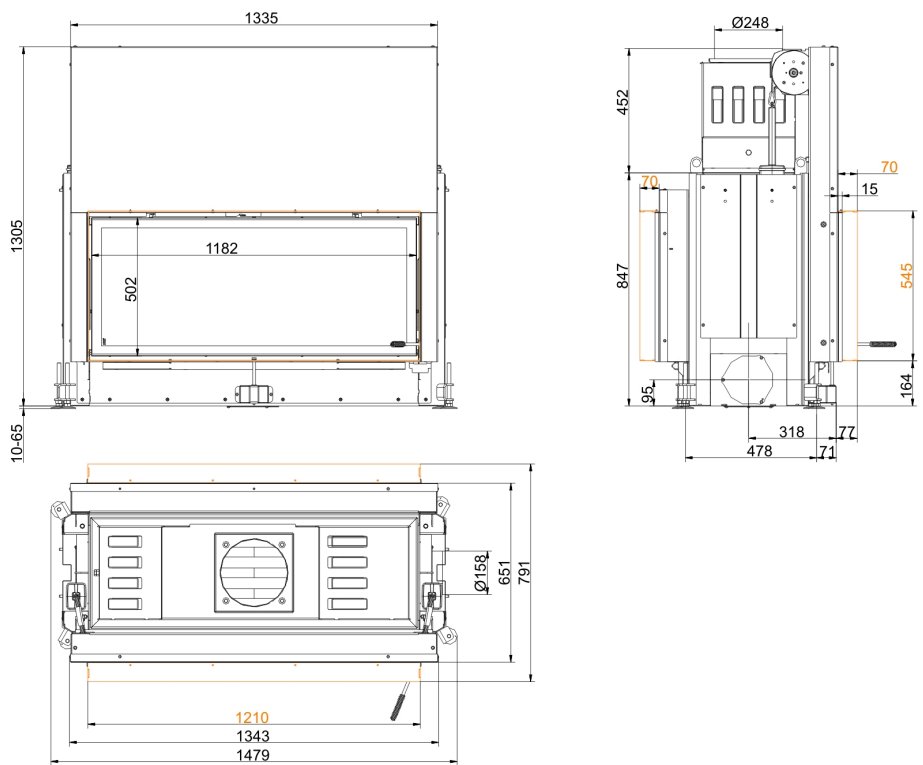

... /tilting door with mounting frame 70 mm

Dimension sheets - Architektur-Tunnel 53/121

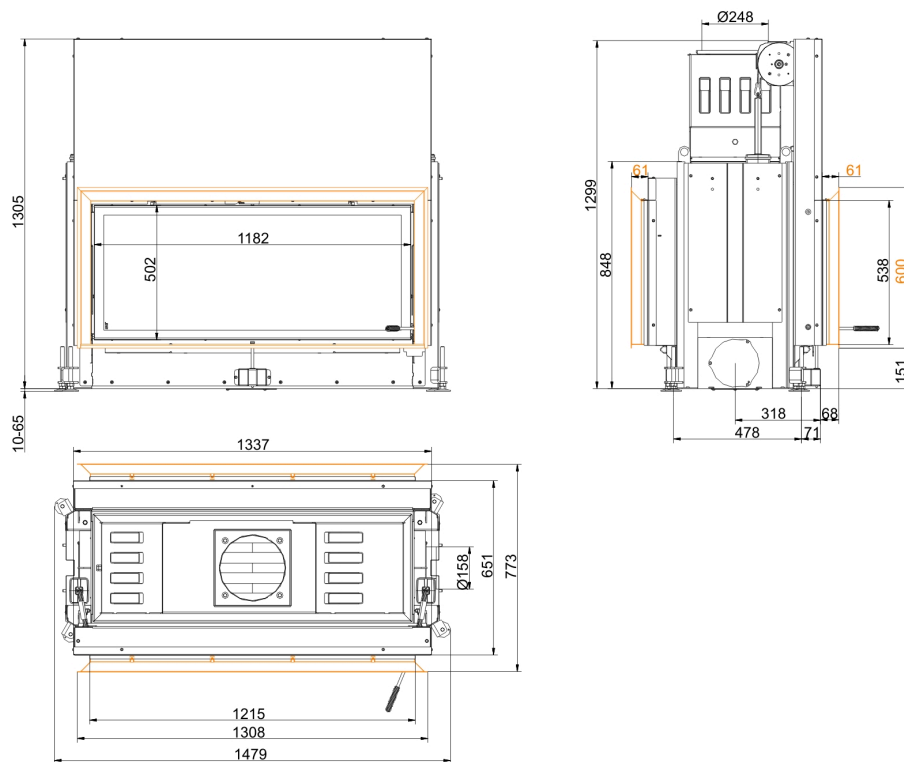

... /tilting door with door frame

We suggest for CAD planning Palette CAD. Permanent updated drawings: www.brunner.de
 Frames/ flue gas outlet connection/ combustion air supply connection/ front variants/ support bearing are marked in color.

Planning and installation - Architektur-Tunnel 53/121

Tested according to		EN 13229 W
Values measured at		Rated power ¹⁾
Suitable for all construction types according to rules		OK
Data for functional demonstration		
Rated heat power	kW	13.5
Fire wood volume	kg/h	4.3
Combustion performance	kW	17
Flue gas mass flow	g/s	12
Flue gas temperature after:		
metallic hot air hood	°C	205
Necessary supply pressure	Pa	12
Combustion air consumption	m ³ /h	45
Combustion air connection Ø	mm	160
Heat distribution		
Insert / reheating surface	%	50 / -
Glass pane (single / double)	%	50 / -
Cross-section of gratings ²⁾		
Convection air	cm ²	800 / 100 / -
Supply air	cm ²	800 / 100 / -
Minimal oven surface for closed construction type		
Heat dissipating surface	m ²	4.5
Minimal distances of the fireplace		
to cladding, insulation layer	cm	6
to mounting floor	cm	2
Thermal insulation without / with air gratings ³⁾		
Mounting wall	cm	16 / 12
Floor	cm	4 / 2
Ceiling	cm	25 / 18
Brick lining for combustible wall	cm	10
Weight		
Fireplace / combustion chamber	kg	354 / 81 / -
Meets requirement/limit values for:		
Germany/ Austria / Switzerland / Norway		1.BImSchV (Stufe 2) / 15a BvG (2015) / LRV / -

- 1) Indications to "Rated power" determined with metallic reheating surface
- 2) for fireplace inserts / flue gas pipe / metallic reheating surface
- 3) Values determined with upper air cross-sections; stove cladding is heat emitting.

Dimension sheets - Architektur 53/166 lifting door

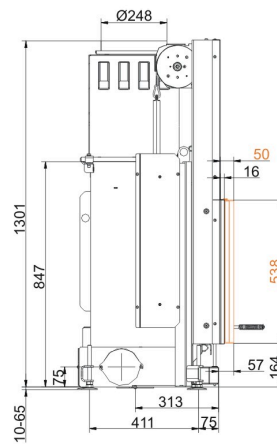
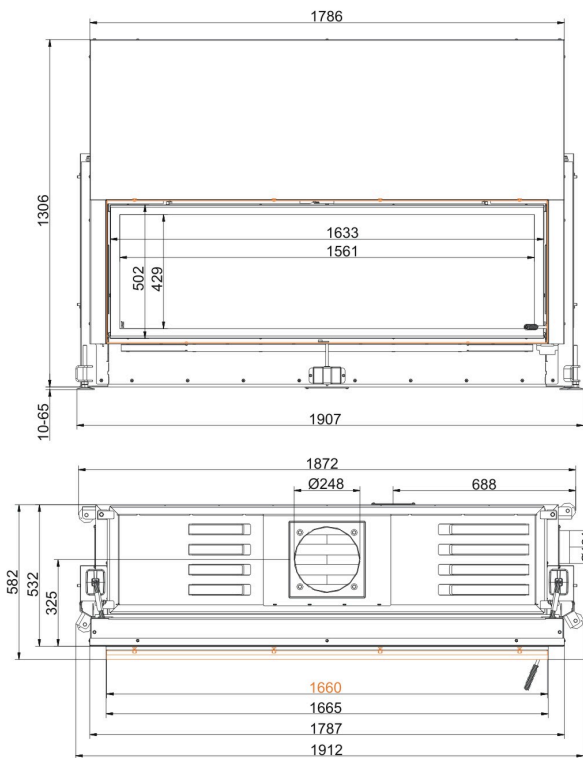

... with mounting frame 50 mm

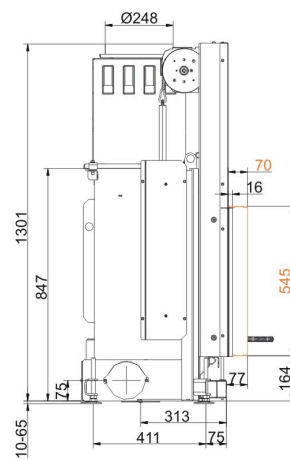
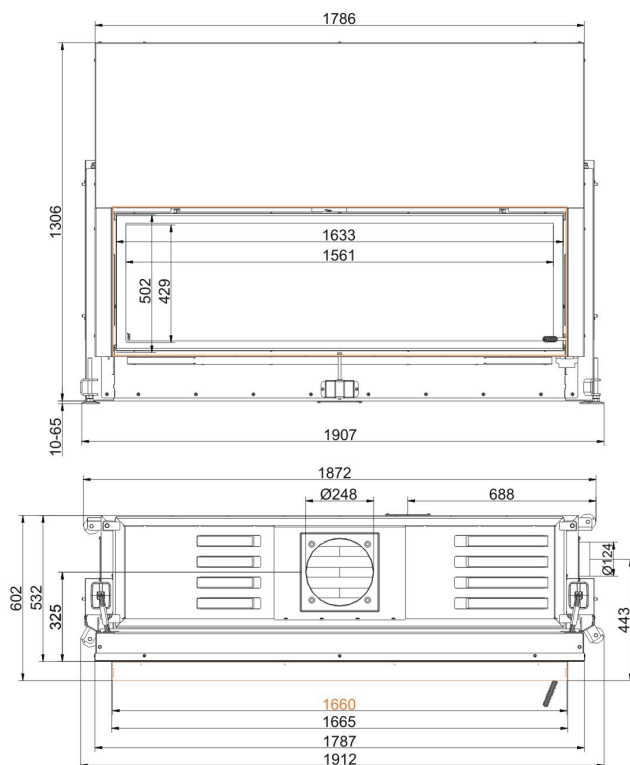

... with mounting frame 70 mm

Planning and installation - Architektur 53/166 lifting door

Tested according to		EN 13229 W
Values measured at		Rated power ¹⁾
Suitable for all construction types according to rules		OK
Data for functional demonstration		
Rated heat power	kW	17
Fire wood volume	kg/h	4.3
Combustion performance	kW	21
Flue gas mass flow	g/s	14.5
Flue gas temperature after:		
metallic hot air hood	°C	230
Necessary supply pressure	Pa	13
Combustion air consumption	m ³ /h	50
Combustion air connection Ø	mm	125
Heat distribution		
Insert / reheating surface	%	60 / -
Glass pane (single / double)	%	40 / -
Cross-section of gratings ²⁾		
Convection air	cm ²	900 / 100 / -
Supply air	cm ²	900 / 100 / -
Minimal oven surface for closed construction type		
Heat dissipating surface	m ²	7.5
Minimal distances of the fireplace		
to cladding, insulation layer	cm	6
to mounting floor	cm	2
Thermal insulation without / with air gratings ³⁾		
Mounting wall	cm	16 / 12
Floor	cm	4 / 2
Ceiling	cm	25 / 18
Brick lining for combustible wall	cm	10
Weight		
Fireplace / combustion chamber	kg	382 / 150
Meets requirement/limit values for:		
Germany/ Austria / Switzerland / Norway		1.BImSchV (Stufe 2) / 15a BVG (2015) / LRV / NS 3059

- 1) Indications to "Rated power" determined with metallic reheating surface
- 2) for fireplace inserts / flue gas pipe / metallic reheating surface
- 3) Values determined with upper air cross-sections; stove cladding is heat emitting.

Dimension sheets - Architektur-Tunnel 53/166

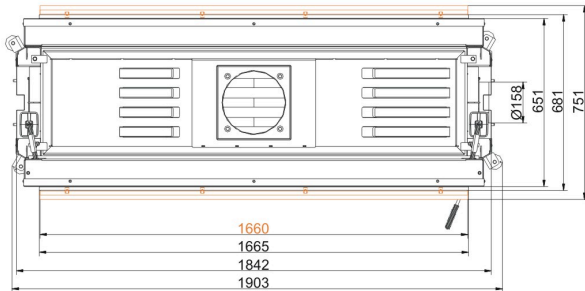
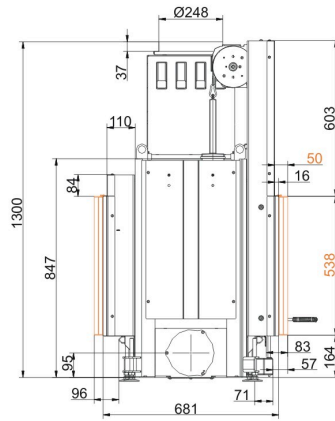
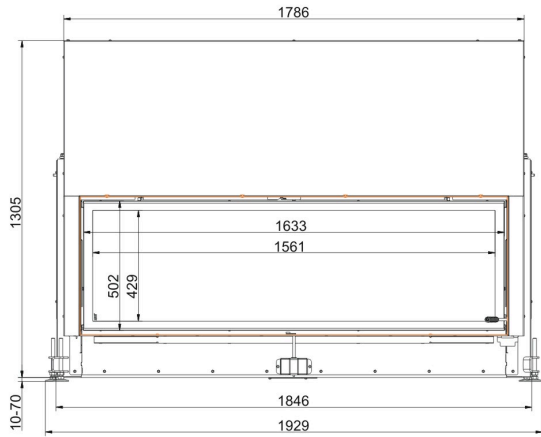

... /tilting door with mounting frame 50 mm

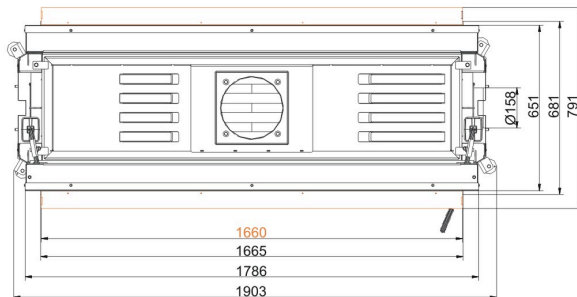
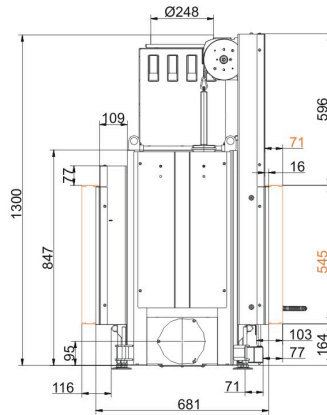
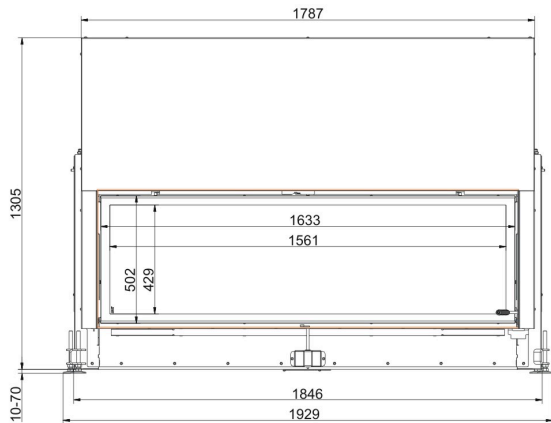

... /tilting door with mounting frame 70 mm

Dimension sheets - Architektur-Tunnel 53/166

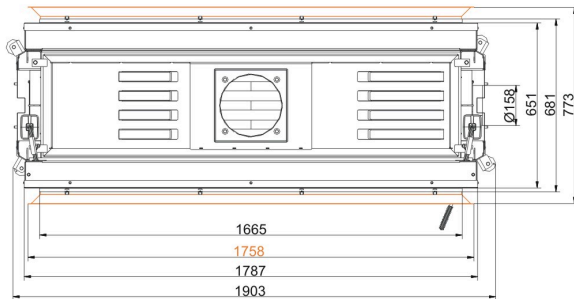
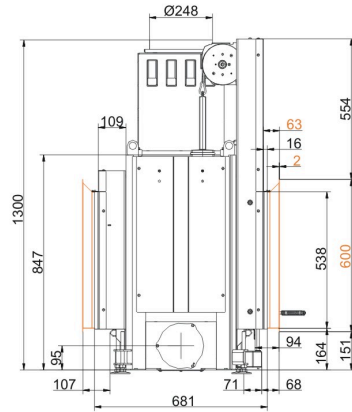
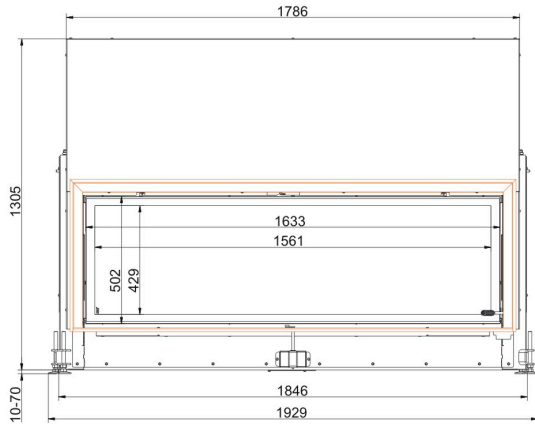

... /tilting door with door frame

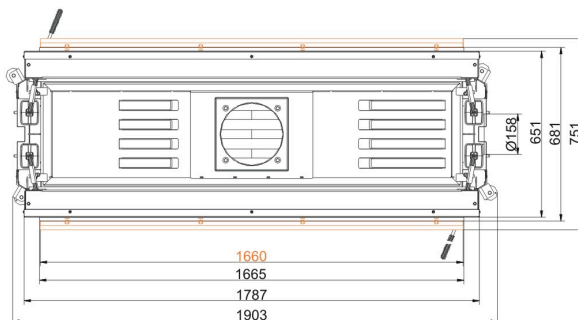
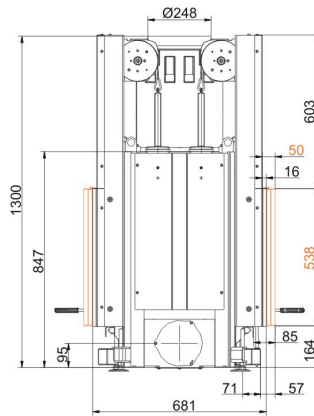
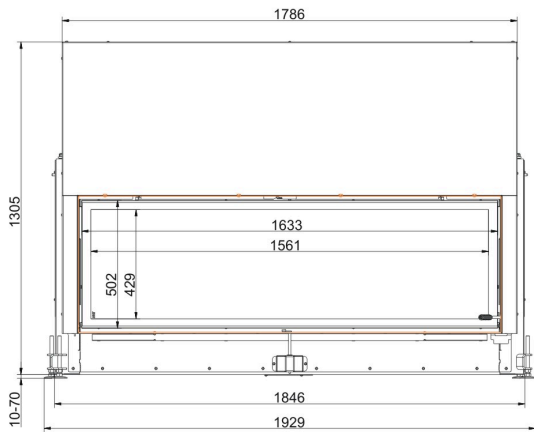

... with mounting frame 50 mm

Dimension sheets - Architektur-Tunnel 53/166

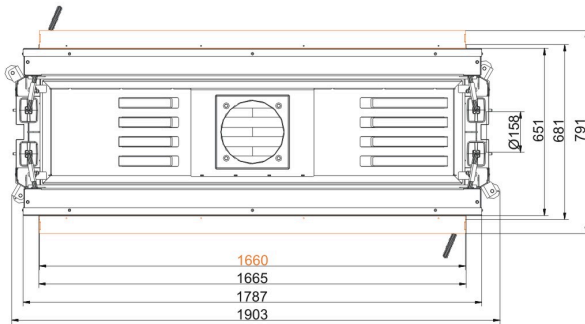
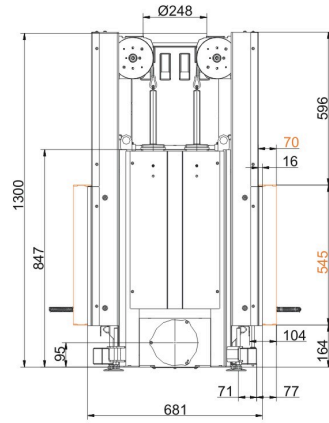
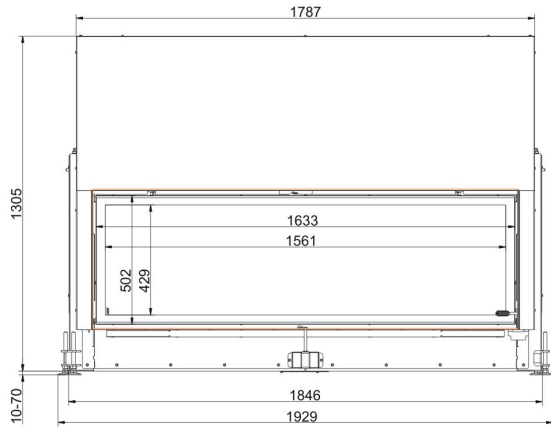

... with mounting frame 70 mm

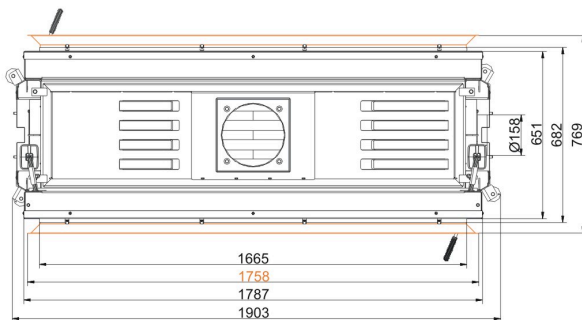
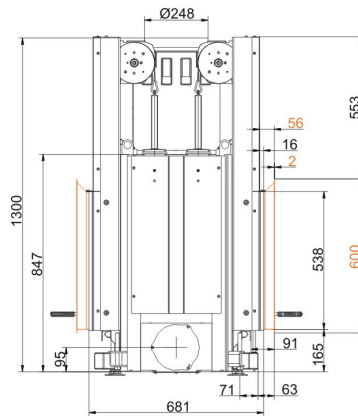
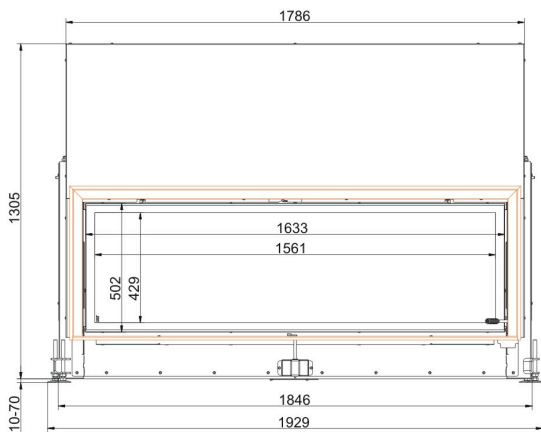

... with door frame

We suggest for CAD planning Palette CAD. Permanent updated drawings: www.brunner.de
 Frames/ flue gas outlet connection/ combustion air supply connection/ front variants/ support bearing are marked in color.

Planning and installation - Architektur-Tunnel 53/166

Tested according to		EN 13229 W
Values measured at		Rated power ¹⁾
Suitable for all construction types according to rules		OK
Data for functional demonstration		
Rated heat power	kW	17
Fire wood volume	kg/h	4.3
Combustion performance	kW	21
Flue gas mass flow	g/s	14.5
Flue gas temperature after:		
metallic hot air hood	°C	225
Necessary supply pressure	Pa	13
Combustion air consumption	m ³ /h	50
Combustion air connection Ø	mm	160
Heat distribution		
Insert / reheating surface	%	50 / -
Glass pane (single / double)	%	50 / -
Cross-section of gratings ²⁾		
Convection air	cm ²	900 / 100 / -
Supply air	cm ²	900 / 100 / -
Minimal oven surface for closed construction type		
Heat dissipating surface	m ²	5.5
Minimal distances of the fireplace		
to cladding, insulation layer	cm	6
to mounting floor	cm	2
Thermal insulation without / with air gratings ³⁾		
Mounting wall	cm	16 / 12
Floor	cm	4 / 2
Ceiling	cm	25 / 18
Brick lining for combustible wall	cm	10
Weight		
Fireplace / combustion chamber	kg	436 / 99
Meets requirement/limit values for:		
Germany/ Austria / Switzerland / Norway		1.BImSchV (Stufe 2) / 15a BvG (2015) / LRV / -

- 1) Indications to "Rated power" determined with metallic reheating surface
- 2) for fireplace inserts / flue gas pipe / metallic reheating surface
- 3) Values determined with upper air cross-sections; stove cladding is heat emitting.

Product data sheet according to (EU) 2015/1186:

Supplier's name or trademark	Ulrich Brunner GmbH
Model identifier:	Architektur 38/86
Energy efficiency class:	A
Direct heat output:	10,0 kW
Indirect heat output:	N.A. kW
Energy efficiency index:	107
Fuel energy efficiency (at nominal heat output):	81,0 %
Fuel energy efficiency (at minimum load):	N.A. %
Special precautions: see supplied product documentation	

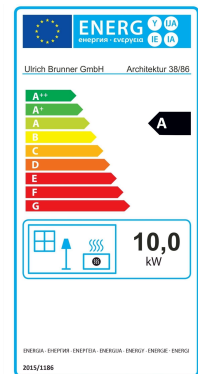

Product data sheet according to (EU) 2015/1186:

Supplier's name or trademark	Ulrich Brunner GmbH
Model identifier:	Architektur Tunnel 38/86
Energy efficiency class:	A
Direct heat output:	10,0 kW
Indirect heat output:	N.A. kW
Energy efficiency index:	107
Fuel energy efficiency (at nominal heat output):	81,0 %
Fuel energy efficiency (at minimum load):	N.A. %
Special precautions: see supplied product documentation	

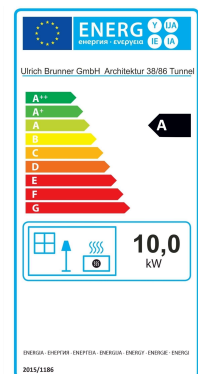

Product data sheet according to (EU) 2015/1186:

Supplier's name or trademark	Ulrich Brunner GmbH
Model identifier:	Architektur 45/101
Energy efficiency class:	A
Direct heat output:	14,0 kW
Indirect heat output:	N.A. kW
Energy efficiency index:	107
Fuel energy efficiency (at nominal heat output):	81,0 %
Fuel energy efficiency (at minimum load):	N.A. %
Special precautions: see supplied product documentation	

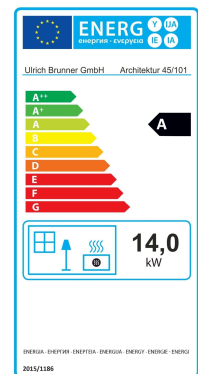

Product data sheet according to (EU) 2015/1186:

Supplier's name or trademark	Ulrich Brunner GmbH
Model identifier:	Architektur Tunnel 45/101
Energy efficiency class:	A
Direct heat output:	14,0 kW
Indirect heat output:	N.A. kW
Energy efficiency index:	107
Fuel energy efficiency (at nominal heat output):	81,0 %
Fuel energy efficiency (at minimum load):	N.A. %
Special precautions: see supplied product documentation	

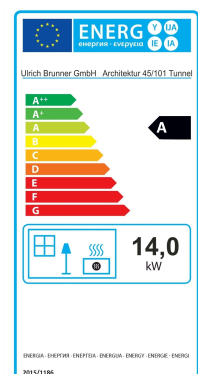

Ulrich Brunner GmbH
Zellhuber Ring 17-18
D-84307 Eggenfelden
Tel.: +49 (0) 8721/771-0 / Fax: +49 (0) 8721/771-100
Email: info@brunner.de

Technical and assortment changes as well as errors and misprints reserved.

Reprinting and reproduction, even in part, only with the express permission of the publisher.

Art.Nr.: 19980